

Agilent Technologies 8935 Series E6381A CDPD Mobile Data Base Station Test Set

Users Guide

For use with the E6381A Option 003 TDMA Test Set

Firmware Version A.02.01 and above



Agilent Technologies

Manufacturing Part Number: E6381-90031

**Revision C
Printed in UK
January 2001**

Notice

Information contained in this document is subject to change without notice.

All Rights Reserved. Reproduction, adaptation, or translation without prior written permission is prohibited, except as allowed under the copyright laws.

This material may be reproduced by or for the U.S. Government pursuant to the Copyright License under the clause at DFARS 52.227-7013 (APR 1988).

© Copyright Agilent Technologies 1997 - 2001

Contents

General Information

How to Use This Manual	8
What is Not Discussed in this Manual	10
Conventions Used in This Manual	11
Using the USER Keys to Select Menu Items	12
Manufacturer's Declaration	13
Safety Considerations	14
Safety Considerations for This Instrument	15
Product Markings	19
Certification	20
Agilent Technologies Warranty Statement for Commercial Products	22
Assistance	24
Trademark Acknowledgements	26

Getting Started

Introduction	28
Using the "Demo" Mode to Explore	28
Required Equipment	29
Test Set Operation	30
Accuracy of This "Getting Started" Procedure	30
Making Your First Measurements	31
Step 1 - Load and Run the Software	31
Step 2 - Select the Desired Test	33
Step 3 - Follow the Displayed Directions	34
Troubleshooting	35

Product Description

What the CDPD Software is and What it Does	43
Procedures on the OTP PC Card	43
What Is Shipped With the E6381A Option 003	44
Software and Firmware Upgrades	46
To Check Your Firmware, Software, and Test Set Code Revisions	46
Additional Information	47
Programming Information	47
Agilent Technologies E6381A Operation	47
Repair Information	47

Test Descriptions

Test Descriptions	51
1. GN Main Menu (accesses all tests)	53
2. Cable/Diversity Splitter Loss Measurement	54
3. Power Measurement Calibration (Agilent Technologies E6381A)	55

4. GMSK Deviation Calibration (Agilent Technologies E6381A)	56
5. Center Frequency Calibration (Agilent Technologies E6381A)	56
6. TX Test (all)	57
7. RX Forward Channel Control Flag	59
8. RX Busy Set Threshold (set-and-measure)	60
9. RX Busy Set Threshold (iterative)	61
10. RX Busy Set Threshold [w/training]	62
11. RX Sensitivity (set-and measure)	62
12. RX Sensitivity (set/meas, +/- 3 kHz)	63
13. RX Sensitivity (iterative)	64
14. Sniffer Threshold (set-and-measure)	64
15. Sniffer Threshold (iterative)	65
16. Sniffer Activation Time	65
17. Display CSI PDU	66
18. Display CC PDU	68
19. Display CQP PDU	70
Parameters Used for This Test	70
20. Display CAP PDU	71
Parameters Used for This Test	71
21. Display All PDUs	72
Parameters Used for This Test	72
22. Software/Firmware Revision Info	72
Test Parameters	
Test Parameters Descriptions	74
1. GN Signals Present [0=single,1=many]	76
2. GN sound BEEP in menu [0=no/1=yes]	76
3. GN System [1=A system, 2=B sys, 0=both]	76
4. GN Testset Input Port [0=RF IN/1=ANT IN]	77
5. RX Busy Set Threshold (set-and-measure)	77
6. RX Busy Set Threshold max level to test	77
7. RX Busy Set Threshold min level to test	77
8. RX Busy/Idle Flag template [0 to 10]	78
9. RX Cable and Diversity Splitter loss	79
10. RX Decode Stat timing [0=norm/1=relaxed]	80
11. RX Decode Status Flag template [0 to 10]	80
12. RX Fwd Channel Control Flag test level	81
13. RX LNA Gain	81
14. RX Sensitivity level (set-and-measure)	81
15. RX Sensitivity max level to test	82
16. RX Sensitivity min level to test	82

Contents

17. RX Sensitivity test frequency offset	82
18. RX Sensitivity test MAX_BLOCK [64 max]	82
19. RX Splitter/Coupler loss	82
20. RX Test Diversity [0=no, 1=yes]	83
21. Sniffer Injection Level (to test timing)	83
22. Sniffer Port Pad (Optional)	83
23. Sniffer Sensitivity (set-and-measure)	83
24. Sniffer Sensitivity max level to test	83
25. Sniffer Sensitivity min level to test	83
26. TX Cable Loss	84
27. TX Channel Power	84
28. TX Splitter/Coupler loss	85
29. Demonstration Mode [0=normal, 1=demo]	85
Test Specifications	
Viewing and Changing Test Specifications	88
Default Values	91
1. RX Busy Set Threshold (iterative method)	92
2. RX Sensitivity (iterative method)	92
3. Sniffer Activation Time	92
4. Sniffer Sensitivity (iterative method)	92
5. Sniffer Test Residual TX Level	92
6. TX Adjacent Channel Power	92
7. TX Channel Power Tolerance	93
8. TX First Alternate Channel Power	93
9. TX Frequency Error	93
10. TX Incidental FM	93
11. TX Modulation Index	93
12. TX Second Alternate Channel Power	94
Test System Configuration	
Suggested Configuration Process	96
Accessing Configuration Screens	97
Required Configuration	99
Optional Configuration	100
Creating Your Own Test Sequence	100
Changing Test Execution Conditions	103
Printing	105
Supported Printers	105
Printer Connection	106
To Setup the Printer	106
Connecting External Devices	110
Data Collection (Saving and Retrieving Test Results)	110
Collection to a PC Card	110

Contents

Data Collection to a PC	112
Configuration for Terminal Operation	114
PC Cards (Memory Cards, PCMCIA Cards)	115
SRAM PC (Memory) Cards	116
PC Card Storage Space	117
Initializing a PC Card	117
How to Save/Delete Procedures	118
How to Save a Test Procedure	118
Standard Formulas and Conversions 123	
Standard Formulas and Conversions	124

1 General Information

This manual explains how to install and use the Cellular Digital Packet Data (CDPD) Mobile Data Base Station (MDBS) Test software. Procedures for specific CDPD base station tests are explained, along with additional information related to common software tasks.

How to Use This Manual

Step 1. Do This First!

Read [Chapter 2](#) , “Getting Started,” on page 27, completely to get you started testing without a lot of reading.

"Getting Started" explains the following:

- the basic process for using the software
- using the "demo mode" to imitate base station testing without having a real base station connected to the system
- how to install the software
- how to quickly perform a sample transmitter test
- what to do if something goes wrong in the installation or quick test

Step 2. Read [Chapter 3](#) , “Product Description,” on page 41 to get a brief product overview.

Step 3. Read [Chapter 7](#) , “Test System Configuration,” on page 95 to review required and optional software operations.

"Test System Configuration" explains the following:

- how to create your own test procedure from available tests
- how to change the way test results are displayed
- how to connect devices to the Serial and Parallel ports for printing and other data functions
- learn how to log data to a printer on a database/spreadsheet
- learn how to set up the test set to automatically start the software when the unit is switched on

Step 4. Scan [Chapter 4](#) , “Test Descriptions,” on page 49 to see what’s required to perform each test.

Each test description explains the following:

- what tests can be performed with the software
- how the tests are performed using the software
- what connections are needed for each test
- any software configuration affecting each test

Step 5. Use [Chapter 5](#) , “Test Parameters,” on page 73 to understand how to alter software operation to maximize test accuracy and best conform to your test situation.

- Step 6.** Use [Chapter 6](#) , “[Test Specifications](#),” on page [87](#) to understand how to enter pass/fail limits for each measurement.
- Step 7.** [Appendix](#) , “[Standard Formulas and Conversions](#),” on page [124](#) contains some common formulas for calculating power levels, or for converting power levels from one unit of measure to another.
- Step 8.** Use the “[Glossary](#)” and “[Index](#)” for definitions and cross-referencing.

What is *Not* Discussed in this Manual

- How to use the CDPD screen's manual user interface. That screen exists solely to allow the Agilent Technologies CDPD software to operate, and is not intended for direct customer use.
- How to control your CDPD base station, switch system, or any other software or hardware associated with your cell site equipment. Manufacturers and cellular service providers have their own cell site control and base station configuration procedures that go beyond the scope of this documentation.
- How to troubleshoot a failing base station after you have verified that the CDPD software and test hardware are operating properly. You must refer to your base station's documentation to determine the cause of the fault.
- How to perform IBASIC programming operations, such as writing, editing, copying, or cataloguing programs. Programming the Agilent Technologies 8935 Series E6381A IBASIC controller is described in the *Programmer's Guide* and *Syntax Reference Guide*.
- How to test any other type of base station or mobile radio; such as AMPS, N-AMPS, TACS, E-TACS, TDMA, or CDMA.

Conventions Used in This Manual

The following conventions are used throughout this manual to help clarify instructions and reduce unnecessary text:

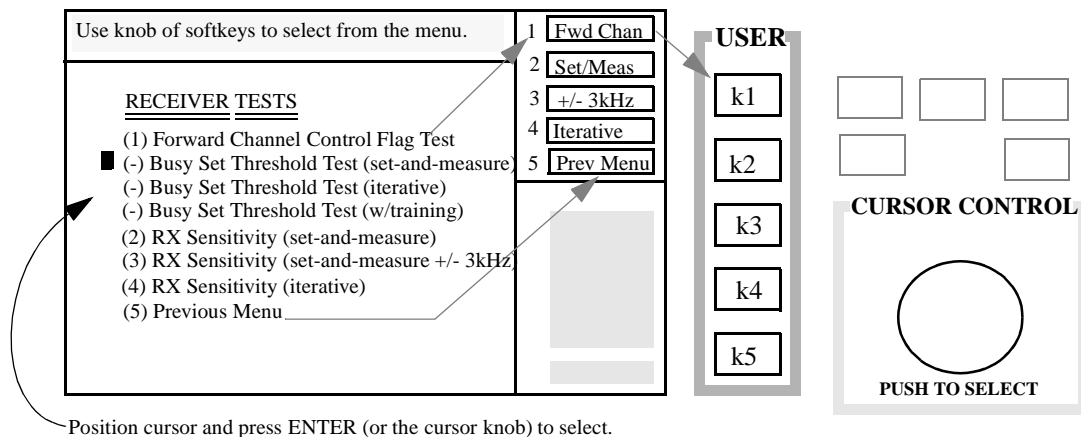
- Test Set refers to the Agilent Technologies 8935 Series E6381A equipped with CDPD test hardware (Option 003) and CDPD software.
- MDBS is the Mobile Data Base Station you are testing.
- Test Set keys are indicated like this: **Preset**
- Test Set screen information, such as a measurement result or an error message, is shown like this: TX Channel Power -1.3 dBm

Using the USER Keys to Select Menu Items

The five USER keys next to the display are assigned to various menu items. Key assignments are indicated in the top-right corner of the display. In this example, pressing **k1** provides an alternate method of selecting Forward Channel Control Flag Test; **k5** is used to select Previous Menu, and so on.

If a menu item that is displayed on the screen does not appear on the USER key assignment (such as when six or more items are available), you must select the unassigned functions using the cursor and knob.

Figure 1-1



Manufacturer's Declaration

This statement is provided to comply with the requirements of the German Sound Emission Directive, from 18 January 1991.

This product has the following sound pressure emission specification:

- sound pressure $L_p < 70$ dB(A)
- at the operator position
- under normal operation
- according to ISO 7779:1988/EN 27779:1991 (Type Test).

Herstellerbescheinigung

Diese Information steht im Zusammenhang mit den Anforderungen der Maschinenlärminformationsverordnung vom 18 Januar 1991.

- Schalldruckpegel $L_p < 70$ dB(A).
- Am Arbeitsplatz.
- Normaler Betrieb.
- Nach ISO 7779:1988/EN 27779:1991 (Typprüfung).

Safety Considerations

GENERAL

This product and related documentation must be reviewed for familiarization with safety markings and instructions before operation.

This product has been designed and tested in accordance with IEC Publication 61010-1+A1+A2:1992 Safety Requirements for Electrical Equipment for Measurement, Control and Laboratory Use and has been supplied in a safe condition. This instruction documentation contains information and warnings which must be followed by the user to ensure safe operation and to maintain the product in a safe condition.

SAFETY EARTH GROUND

A uninterruptible safety earth ground must be provided from the main power source to the product input wiring terminals, power cord, or supplied power cord set.

CHASSIS GROUND TERMINAL

To prevent a potential shock hazard, always connect the rear-panel chassis ground terminal to earth ground when operating this instrument from a dc power source.

SAFETY SYMBOLS



Indicates instrument damage can occur if indicated operating limits are exceeded. Refer to the instructions in this guide.



Indicates hazardous voltages.



Indicates earth (ground) terminal

WARNING

A WARNING note denotes a hazard. It calls attention to a procedure, practice, or the like, which, if not correctly performed or adhered to, could result in personal injury. Do not proceed beyond a WARNING sign until the indicated conditions are fully understood and met.

CAUTION

A CAUTION note denotes a hazard. It calls attention to an operation procedure, practice, or the like, which, if not correctly performed or adhered to, could result in damage to or destruction of part or all of the product. Do not proceed beyond an CAUTION note until the indicated conditions are fully understood and met.

Safety Considerations for This Instrument

WARNING

Whenever it is likely that the protection has been impaired, the instrument must be made inoperative and be secured against any unintended operation.

If this instrument is to be energized via an autotransformer (for voltage reduction), make sure the common terminal is connected to the earth terminal of the power source.

If this product is not used as specified, the protection provided by the equipment could be impaired. This product must be used in a normal condition (in which all means for protection are intact) only.

No operator serviceable parts in this product. Refer servicing to qualified personnel. To prevent electrical shock, do not remove covers.

Servicing instructions are for use by qualified personnel only. To avoid electrical shock, do not perform any servicing unless you are qualified to do so.

The opening of covers or removal of parts is likely to expose dangerous voltages. Disconnect the product from all voltage sources while it is being opened.

Adjustments described in the manual are performed with power supplied to the instrument while protective covers are removed. Energy available at many points may, if contacted, result in personal injury.

For Continued protection against fire hazard, replace the line fuse(s) with T 250 V 5.0 A fuse(s) or the same current rating and type. Do not use repaired fuses or short circuited fuseholders.

WARNING



This product is a Safety Class I instrument (provided with a protective earthing ground incorporated in the power cord). The mains plug shall only be inserted in a socket outlet provided with a protective earth contact. Any interruption of the protective conductor inside or outside of the product is likely to make the product dangerous. Intentional interruption is prohibited.

WARNING

Always use the three-prong ac power cord supplied with this product. Failure to ensure adequate earth grounding by not using this cord may cause personal injury and/or product damage.

This product is designed for use in Installation Category II and Pollution Degree 3 per IEC 61010 and IEC 60664 respectively.

This product has autoranging line voltage input, be sure the supply voltage is within the specified range.

To prevent electrical shock, disconnect instrument from mains (line) before cleaning. Use a dry cloth or one slightly dampened with water to clean the external case parts. Do not attempt to clean internally.

Ventilation Requirements: When installing the product in a cabinet, the convection into and out of the product must not be restricted. The ambient temperature (outside the cabinet) must be less than the maximum operating temperature of the product by 4° C for every 100 watts dissipated in the cabinet. If the total power dissipated in the cabinet is greater than 800 watts, then forced convection must be used.

WARNING

RUBIDIUM REFERENCE ASSEMBLY

The optional Rubidium Reference assembly of the Test Set contains the radioactive isotope Rubidium 87. This assembly contains no user serviceable parts. DO NOT attempt to repair it. There is no measurable external radiation. This assembly does not present a safety hazard. This assembly is regulated as a hazardous waste and must be disposed of in accordance with local, state, and federal regulations. For important shipping information, see

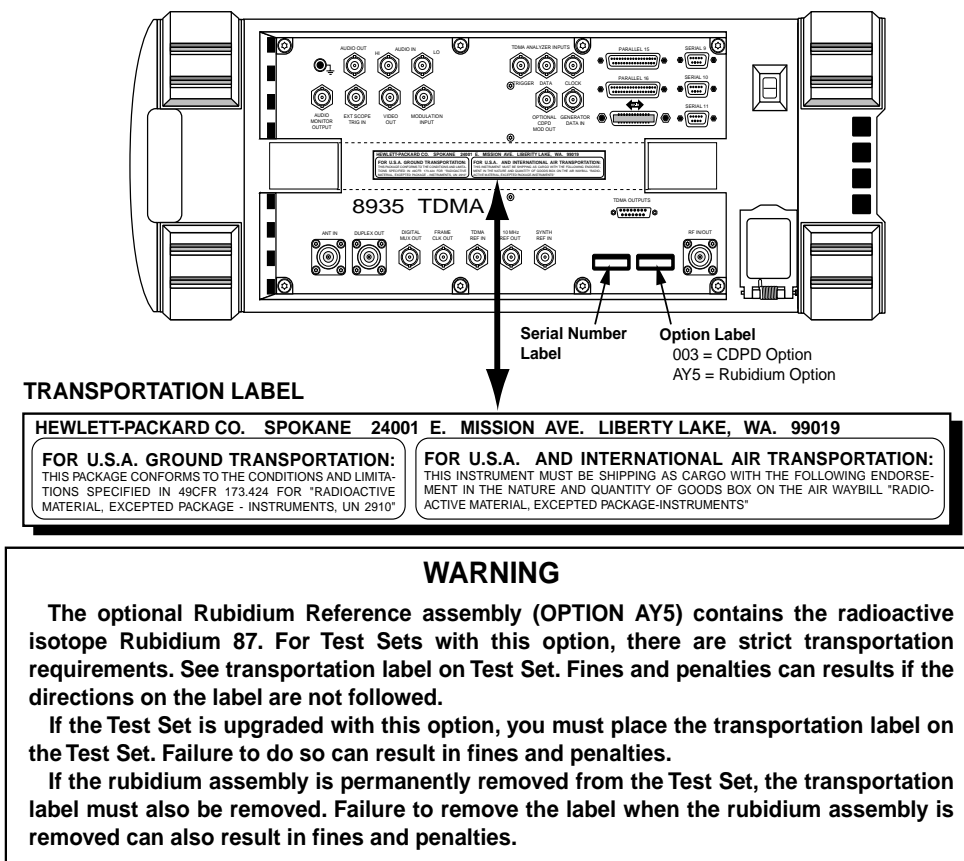
FOR GROUND TRANSPORTATION IN THE U.S.A.:

This package conforms to the conditions and limitations specified in 49CFR 173.424 for radioactive material, excepted package – instruments, UN2910.

FOR AIR TRANSPORTATION IN THE U.S.A. AND INTERNATIONAL:

This instrument must be shipped as cargo with the following endorsement in the nature and quantity of goods box on the air waybill, “Radioactive material, excepted package – instruments.”

Figure 1 Rubidium Transportation Labels



Lifting and Handling

When lifting and handling the Agilent 8935 TDMA Cellular/PCS Base Station Test Set use ergonomically correct procedures. Lift and carry by the strap on the side panel.

When moving the Test Set more than a few feet, be sure to replace the front screen cover.

Consumables

Two AA alkalyne batteries are supplied with the Test Set and must be replaced periodically. When replacing batteries always dispose of old batteries in a conscientious manner, following manufacturer's instructions.

Product Markings



The CE mark shows that the product complies with all relevant European legal Directives (if accompanied by a year, it signifies when the design was proven).



The CSA mark is a registered trademark of the Canadian Standards Association.

Certification

Agilent Technologies certifies that this product met its published specifications at the time of shipment from the factory. Agilent further certifies that its calibration measurements are traceable to the United States National Institute of Standards and Technology, to the extent allowed by the Institute's calibration facility, and to the calibration facilities of other International Standards Organization members.

DECLARATION OF CONFORMITY

According to ISO/IEC Guide 22 and CEN/CENELEC EN45014

Manufacturer's Name: Agilent Technologies UK Limited

Manufacturer's Address: Electronic Products Solutions Group - Queensferry
South Queensferry
West Lothian, EH30 9TG
Scotland, United Kingdom

Declares that the product

Product Name: TDMA PCS Base Station Test Set

Model Number: E6381A

Product Options: This declaration covers all options of the above product as detailed in TCF A-5951-9852-02.

EMC:

Conforms with the protection requirements of European Council Directive 89/336/EEC on the approximation of the laws of the member states relating to electromagnetic compatibility, against EMC test specifications EN 55011:1991 (Group 1, Class A) and EN 50082-1:1992.

As Detailed in: Electromagnetic Compatibility (EMC)
Technical Construction File (TCF) No. A-5951-9852-02.

Assessed by: DTI Appointed Competent Body
EMC Test Centre,
GEC-Marconi Avionics Ltd.,
Maxwell Building,
Donibristle Industrial Park,
Hillend,
Dunfermline
KY11 9LB
Scotland, United Kingdom

Technical Report Number:6893/2201/CBR, dated 23 September 1997

Safety:

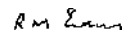
The product conforms to the following safety standards:

IEC 61010-1(1990) +A1(1992) +A2(1995) / EN 61010-1:1993
IEC 60825-1(1993) / EN 60825-1:1994
Canada / CSA-C22.2 No. 1010.1-93

The product herewith complies with the requirements of the Low Voltage Directive 73/23/EEC, and carries the CE mark accordingly

South Queensferry, Scotland.

1st November 2000



R.M. Evans / Manufacturing
Engineering Manager

For further information, please contact your local Agilent Technologies sales office, agent, or distributor.

Agilent Technologies Warranty Statement for Commercial Products

E6381A TDMA/Cellular PCS Base Station Test Set

**Duration of
Warranty: 1 Year**

1. Agilent warrants Agilent hardware, accessories and supplies against defects in materials and workmanship for the period specified above. If Agilent receives notice of such defects during the warranty period, Agilent will, at its option, either repair or replace products which prove to be defective. Replacement products may be either new or like-new.
2. Agilent warrants that Agilent software will not fail to execute its programming instructions, for the period specified above, due to defects in material and workmanship when properly installed and used. If Agilent receives notice of such defects during the warranty period, Agilent will replace software media which does not execute its programming instructions due to such defects.
3. Agilent does not warrant that the operation of Agilent products will be uninterrupted or error free. If Agilent is unable, within a reasonable time, to repair or replace any product to a condition as warranted, customer will be entitled to a refund of the purchase price upon prompt return of the product.
4. Agilent products may contain remanufactured parts equivalent to new in performance or may have been subject to incidental use.
5. The warranty period begins on the date of delivery or on the date of installation if installed by Agilent. If customer schedules or delays Agilent installation more than 30 days after delivery, warranty begins on the 31st day from delivery.
6. Warranty does not apply to defects resulting from (a) improper or inadequate maintenance or calibration, (b) software, interfacing, parts or supplies not supplied by Agilent, (c) unauthorized modification or misuse, (d) operation outside of the published environmental specifications for the product, or (e) improper site preparation or maintenance.

7. TO THE EXTENT ALLOWED BY LOCAL LAW, THE ABOVE WARRANTIES ARE EXCLUSIVE AND NO OTHER WARRANTY OR CONDITION, WHETHER WRITTEN OR ORAL IS EXPRESSED OR IMPLIED AND Agilent SPECIFICALLY DISCLAIMS ANY IMPLIED WARRANTIES OR CONDITIONS OR MERCHANTABILITY, SATISFACTORY QUALITY, AND FITNESS FOR A PARTICULAR PURPOSE.
8. Agilent will be liable for damage to tangible property per incident up to the greater of \$300,000 or the actual amount paid for the product that is the subject of the claim, and for damages for bodily injury or death, to the extent that all such damages are determined by a court of competent jurisdiction to have been directly caused by a defective Agilent product.
9. TO THE EXTENT ALLOWED BY LOCAL LAW, THE REMEDIES IN THIS WARRANTY STATEMENT ARE CUSTOMER'S SOLE AND EXCLUSIVE REMEDIES. EXCEPT AS INDICATED ABOVE, IN NO EVENT WILL Agilent OR ITS SUPPLIERS BE LIABLE FOR LOSS OF DATA OR FOR DIRECT, SPECIAL, INCIDENTAL, CONSEQUENTIAL (INCLUDING LOST PROFIT OR DATA), OR OTHER DAMAGE, WHETHER BASED IN CONTRACT, TORT, OR OTHERWISE.

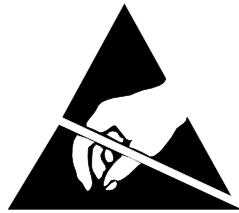
FOR CONSUMER TRANSACTIONS IN AUSTRALIA AND NEW ZEALAND: THE WARRANTY TERMS CONTAINED IN THIS STATEMENT, EXCEPT TO THE EXTENT LAWFULLY PERMITTED, DO NOT EXCLUDE RESTRICT OR MODIFY AND ARE IN ADDITION TO THE MANDATORY STATUTORY RIGHTS APPLICABLE TO THE SALE OF THIS PRODUCT TO YOU.

Assistance

Product maintenance agreements and other customer assistance agreements are available for Agilent Technologies products. For any assistance, contact your nearest Agilent Technologies Sales and Service Office.

Table 1-2 Regional Sales and Service Offices

<p>United States of America: Agilent Technologies Test and Measurement Call Center P.O. Box 4026 Englewood, CO 80155-4026</p> <p>(tel) 1 800 452 4844</p>	<p>Canada: Agilent Technologies Canada Inc. 5150 Spectrum Way Mississauga, Ontario L4W 5G1</p> <p>(tel) 1 877 894 4414</p>	<p>Europe: Agilent Technologies European Marketing Organization P.O. Box 999 1180 AZ Amstelveen The Netherlands</p> <p>(tel) (3120) 547 9999</p>
<p>Japan: Agilent Technologies Japan Ltd. Measurement Assistance Center 9-1 Takakura-Cho, Hachioji-Shi, Tokyo 192-8510, Japan</p> <p>(tel) (81) 456-56-7832 (fax) (81) 426-56-7840</p>	<p>Latin America: Agilent Technologies Latin America Region Headquarters 5200 Blue Lagoon Drive, Suite #950 Miami, Florida 33126 U.S. A.</p> <p>(tel) (305) 267 4245 (fax) (305) 267 4286</p>	<p>Australia/New Zealand: Agilent Technologies Australia Pty Ltd. 347 Burwood Highway Forest Hill, Victoria 3131</p> <p>(tel) 1 800 629 485 (Australia) (fax) (61 3) 9272 0749 (tel) 0 800 738 378 (New Zealand) (fax) (64 4) 802 6881</p>
<p>Asia Pacific: Agilent Technologies 24/F, Cityplaza One, 111 Kings Road, Taikoo Shing, Hong Kong</p> <p>(tel) (852) 3197 7777 (fax) (852) 2506 9233</p>		



ATTENTION

**Static Sensitive
Devices**

This instrument was constructed in an ESD (electro-static discharge) protected environment. This is because most of the semiconductor devices used in this instrument are susceptible to damage by static discharge.

Depending on the magnitude of the charge, device substrates can be punctured or destroyed by contact or mere proximity of a static charge. The result can cause degradation of device performance, early failure, or immediate destruction.

These charges are generated in numerous ways such as simple contact, separation of materials, and normal motions of persons working with static sensitive devices.

When handling or servicing equipment containing static sensitive devices, adequate precautions must be taken to prevent device damage or destruction.

Only those who are thoroughly familiar with industry accepted techniques for handling static sensitive devices should attempt to service circuitry with these devices.

Trademark Acknowledgements

Hewlett-Packard® and HP® are registered trademarks of Hewlett-Packard Company.

Microsoft, Windows®, and MS-DOS®, are registered trademarks of Microsoft Corporation.

ProComm, is a registered trademark of DataStorm Technologies, Inc.

HyperTerminal© is a registered trademark of Hilgraeve, Incorporated.

Pentium® is a registered trademark of Intel Corporation.

2 **Getting Started**

Introduction

In this chapter you will:

- learn the basic process of automated base station testing,
- learn how to load and run the software,
- perform a quick base station test,
- learn how to troubleshoot measurement problems.

Using the “Demo” Mode to Explore

The procedure in this section shows you how to make a real measurement on your MDDBS transmitter. However, it may be helpful to “play” with the software before connecting the Test System to a real MDDBS. A demonstration (“Demo”) mode of operation can be selected to let you explore the software. It operates just like the “real” software, including displaying connection diagrams to the MDDBS, but is not affected by any external connections. This is an excellent way to familiarize yourself with tasks like selecting different types of tests, and lets you see how measurements are displayed with simulated measurement values.

To operate in Demo mode, load the “DEMO” procedure in Step 1 -Load and Run the Software (instead of loading the “CDPD” procedure).

Required Equipment

To be able to duplicate the procedures discussed in this chapter, you need these items:

- ❑ Agilent Technologies E6381A TDMA Test Set equipped with option 003 with the firmware revision displayed on the title page of this document.
- ❑ CDPD Base Station Test software on the factory-supplied Memory Card.
- ❑ BNC and Type-N connectors and cables to connect to your base station and perform the power calibration.
- ❑ A configured CDPD base station (MDBS) with direct access to the Transmit, Receive, and Sniffer ports.

Test Set Operation

The general process discussed in this chapter will help you understand the steps involved in testing any CDPD base station. However, the Test Set provides a very large number of functions not discussed in this manual (such as detailed Spectrum Analyzer operation). For in-depth information on manual Test Set operation, refer to the *Agilent Technologies E6381A TDMA BST Reference Guide*.

Accuracy of This “Getting Started” Procedure

The procedure on the following pages uses the factory default parameter settings, which are generally based on the CDPD standards. However, certain parameters for your system need to be entered to maximize measurement accuracy (such as cable and splitter losses). Unless your transmitter’s signal is very weak, <2 mW (+3 dBm), this procedure should successfully make the necessary transmitter measurements, but the accuracy of the power measurement will probably be somewhat off.

See [Chapter 7](#), “[Test System Configuration](#),” on [page 95](#) to understand what you need to do to make changes to the factory default software settings to match your system, and to understand how to save these changes for future use.

Making Your First Measurements

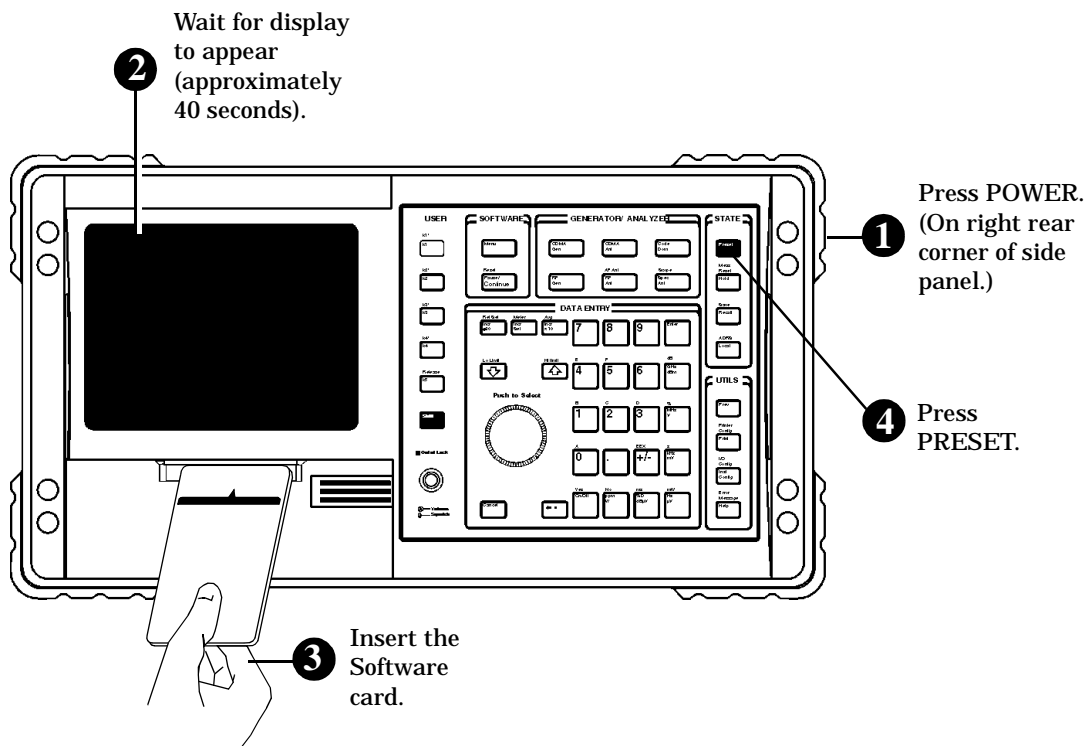
Step 1 - Load and Run the Software

Software is provided on a One-Time-Programmable (OTP) memory card. Follow the instructions below and on the next page.

Before you begin testing, you must load the software into the test set memory. To load the software, you must first select the location to load from (in this case, it will be **Card**) and a procedure filename. Your card comes pre-programmed with at least one procedure. The actual software program does not get loaded into the test set memory until the **K1 USER** key is selected to (**Run Test**).

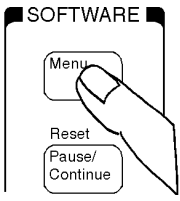
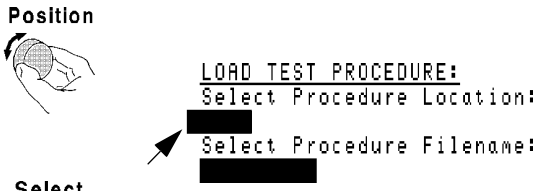

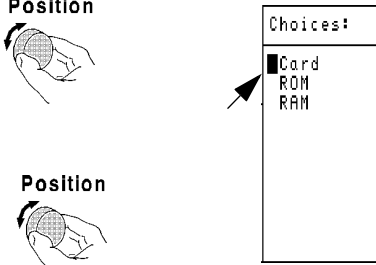

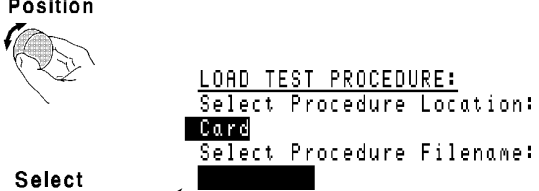

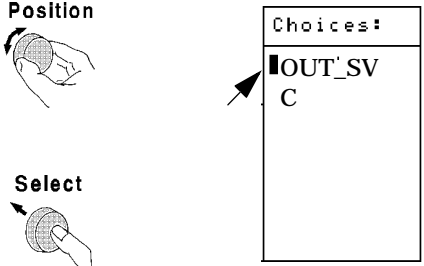

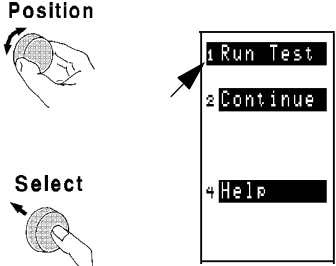


The software memory card can be removed after the program is loaded into the Agilent E6381A memory. The program will remain in memory after a power-down/power-up cycle, unless it is manually deleted or a different program is loaded.

Figure 2-1 Loading and Running the Software



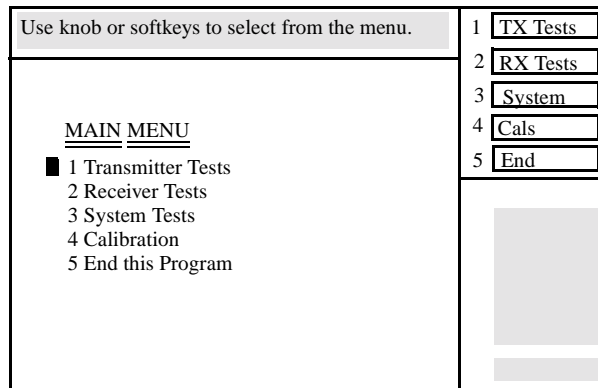
Continued on the following page

Figure 2-2 Loading and Running the Software (Continued)

<p>5 Press the SOFTWARE Menu key to display the Software Menu screen.</p> 	<p>6 Position the cursor at Select Procedure Location: and select it.</p> <p>Position</p>  <p>Select</p> 
<p>7 Position the cursor at Card and select it.</p> <p>Position</p>  <p>Position</p> 	<p>8 Position the cursor at Select Procedure Filename: and select it.</p> <p>Position</p>  <p>Select</p> 
<p>9 Position the cursor at Choices: and select the Procedure name:</p> <p>Position</p>  <p>Select</p> 	<p>10 Position the cursor at Run Test and select it. The Software is now loading.</p> <p>Position</p>  <p>Select</p>  <p>  Loading Time: First time: approximately 15 seconds. After first time: approximately </p>

This screen is displayed if the software loaded and is running correctly. Refer to **“Troubleshooting”** on page 35 if this screen is not displayed after three minutes.

Figure 2-3 Main Menu - what you should see first when the software is loaded and run.



Step 2 - Select the Desired Test

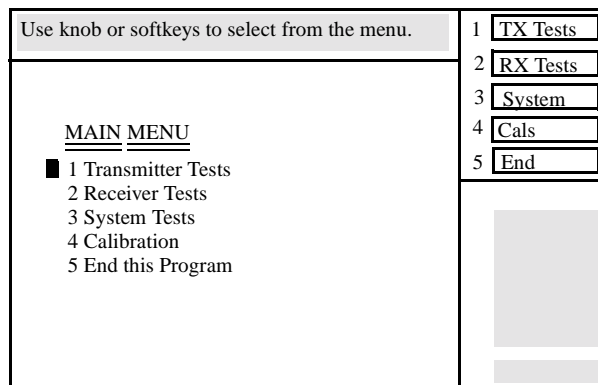
For this *Getting Started* example, we will perform some transmitter tests. Since the cursor is next to the **Transmitter Tests** entry on the screen, you can either:

- push the CURSOR CONTROL knob, or
- press the ENTER key, or
- press the k1 key (see “Conventions Used in This Manual” on page 11)

The **TRANSMITTER TESTS** menu is displayed.

Select **RF Parameters** (power, frequency, etc.) (press the ENTER key or k1 key).

Figure 2-4



Step 3 - Follow the Displayed Directions

A connection diagram and instructions are displayed¹. Perform the indicated connections and select **Continue** (press the **k2** key).

After calibrating, the software proceeds to make several transmitter measurements, including:

- TX Frequency error (Hz)
- TX Frequency error (ppm)
- TX Modulation Index
- TX Power or TX Channel Power
- TX Adjacent Channel Power
- TX First Alternate Channel (power)
- TX Second Alternate Channel (power)
- TX Incidental FM

The software will repeat the test until you tell it return to the previous menu by pressing the **k1 USER** key (or by using the cursor to select the **Menu** item in the top-right corner of the display).

Manual Use of the Test System

CDPD testing must be performed using the CDPD software. After running this software, you should press the **PRESET** key to return the Test Set to its default settings before making any manual measurements on another device.

1. A power calibration routine is performed the first time the software is loaded and transmitter tests are run using the ANT IN port. Once the calibration routine has successfully run, subsequent transmitter tests will bypass this step (even if the Test Set is turned off and back on). If the calibration routine failed for some reason, the software will continue to try to calibrate the power measurement each time the transmitter tests are run. In the future, you can recalibrate the power measurement from the **TRANSMITTER TESTS** menu by selecting **Power Measurement Calibration**.

Troubleshooting

CAUTION

If a loud warbling sound occurs, DISCONNECT THE TRANSMITTER from the Test System immediately! Next, turn the Test Set off to deactivate the alarm. That sound is the overpower warning, occurring when you are putting too much power into the ANT IN or RF IN/OUT port, possibly damaging the Test Set. Disconnect any cables to the ANT IN port before turning the Test Set back on.

If “No Signal Found” is displayed when attempting to test.

- ❑ The MDBS is not transmitting. Verify this by looking at the MDBS status indicators and reset the MDBS to transmit if necessary.
- ❑ The transmitter is not properly connected to the Test System. Verify your connections.

If “No Signal Found” appears intermittently while testing, or transmitter test results imply an intermittent transmitter:

- Verify that the MDBS transmitter is configured for continuous transmission. Some MDBS diagnostic and slow-hop configurations may cause the transmitter to briefly turn off (<100ms), causing apparent test failures. Press the **CANCEL** key to stop the test. Look at the signal on the Test Set’s Spectrum Analyzer to see if the signal is intermittent (press the **SPEC ANL** key). You may have to reduce the **span** setting to see the drop-out. Re-start the program by pressing the **Menu** key and then pressing the **k1 USER** key. You can also turn the **VOLUME** control clockwise and listen to the signal on the Test Set’s internal speaker; you should hear the “buzzing” sound of transmitted data instead of the hiss of white noise.
- Verify that the Sniffer Input is disconnected and terminated properly. Strong local signals may cause the MDBS transmitter to shut down. To minimize the possibility of CDPD to AMPS interference, be sure to disconnect the MDBS transmitter from the cell site equipment **before** disconnecting the Sniffer port.
- Verify that the correct Test System input port is being used for your MDBS transmitter’s power level. Power levels <60 mW require the use of the Test Set’s ANT IN port. Also, parameter “**4. GN Testset Input Port [0=RF IN/1=ANT IN]**” on page 77 must be set to indicate the correct port.

“Busy/Idle” or “Decode Status” errors occur.

These errors occur when your MDDBS is not using the expected CDPD standard encoding format for the Busy/Idle and Decode Status data. The “^” symbol indicates which bits are not correct. The RX Busy/Idle Flag template parameter (see parameter “[8. RX Busy/Idle Flag template \[0 to 10\]](#)” on page 78) and the RX Decode Status timing parameter (“[11. RX Decode Status Flag template \[0 to 10\]](#)” on page 80) list the available bit patterns to use when checking these functions. Change the necessary parameter(s) so that the bits that failed are either not checked or are changed to fit the return bits from your MDDBS.

If none of the available parameter settings corrects the problem, your MDDBS may not be functioning properly.

If the message “Error 80 during Procedure catalog. Catalog aborted.” appears at the top of the screen when trying to load the software:

- The memory card is not inserted correctly. Make sure the card is inserted with the factory label facing up, and that it is inserted completely in the Memory Card slot.
- The memory card is damaged. Replace the card.

If the message “One or more self-tests failed”, a hardware problem exists. Refer to the *Test Set’s Assembly Level Repair* manual. Also, refer to the *Agilent Technologies 8935 Series E6381A BST Reference Guide* for a list of possible error codes

If the message “Unable to perform test. Set parameter(s) for lower levels.” appears: Reduce the value for the parameter “[15. RX Sensitivity max level to test](#)” on page 82 to about 5dB above the expected sensitivity level. To increase measurement speed, set the value for the parameter “RX Sensitivity min level to test” to about 5dB below the expected level. For example, if the expected sensitivity level is -107dBm, set the maximum level to -102dBm and the minimum level to -112dBm.

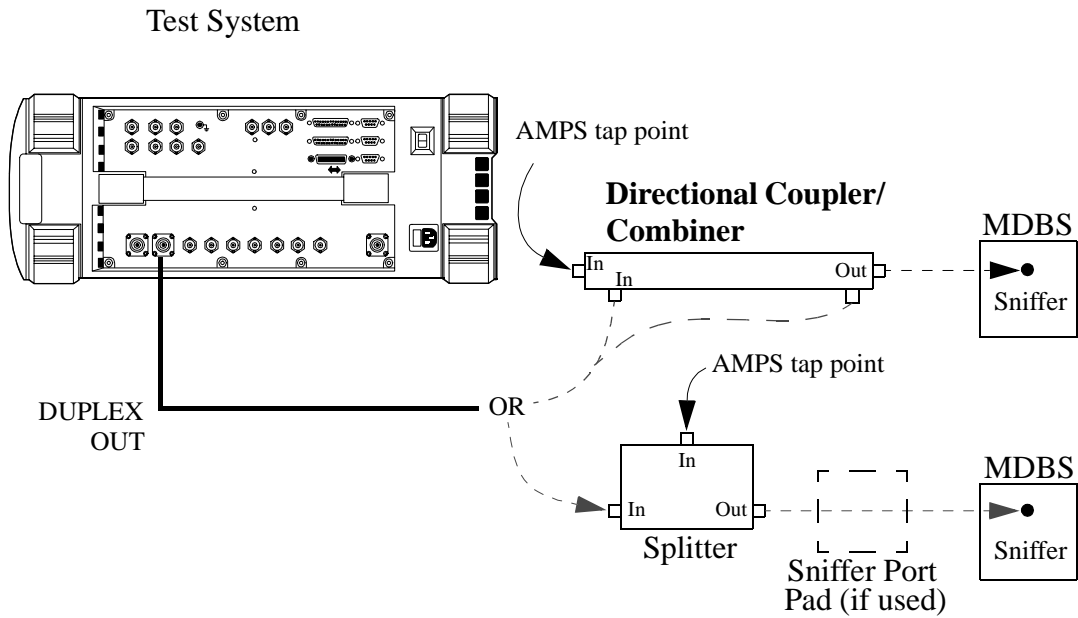
If the MDDBS won’t turn on with the Test Set connected to it:

This can happen if the Test Set is turned on and the DUPLEX OUT port is connected to one of the MDDBS receiver ports. Disconnect the Test Set from the MDDBS and try turning the MDDBS on again.

If the MDBS transmitter turns off when the sniffer is disconnected from the AMPS equipment:

Diagnostic modes for the MDBS may require a continuous AMPS signal on the Sniffer port. Connect the AMPS signal and the Test Set's DUPLEX OUT port to the inputs of a directional coupler or splitter. Connect the coupler/splitter's output to the MDBS Sniffer port. (The AMPS connection should have the least attenuation to the Sniffer port). The loss or coupling through the splitter/coupler for the DUPLEX OUT port's signal should be added together with the Sniffer Pad value and entered in parameter "22. Sniffer Port Pad (Optional)" on page 83.

Figure 2-5 Test System



If Receiver Sensitivity test(s) results seem wrong or are intermittent:

- ❑ The software looks at the Busy/Idle bits and the Decode Status bits transmitted by the MDBS to determine the signal level needed to change their values. The measured sensitivity level depends on the Busy Set threshold programmed into the MDBS. This value may be different than the value entered locally or via the network. Some newly installed MDBSs show a difference between the Busy Set level stored in the MDBS and the desired Busy Set level. The MDBS changes its setting after communicating with Mobile End Stations (M-ESs), causing the two values to approach each other.

Run test [10. RX Busy Set Threshold \[w/training\]](#). This test provides a way to train or raise the Busy Set Threshold towards its configured value.

- ❑ Verify that the following parameters are correctly set for the MDBS being tested:
 - [“8. RX Busy/Idle Flag template \[0 to 10\]”](#) on page 78.
 - [“10. RX Decode Stat timing \[0=norm/1=relaxed\]”](#) on page 80.
 - [“11. RX Decode Status Flag template \[0 to 10\]”](#) on page 80.
- ❑ Verify that the main and diversity antennas are disconnected from the MDBS.
Co-channel signals and M-ES signals can be received by the MDBS, causing erroneous sensitivity measurements.

If an adjacent cell's channel list appears while testing the Cell Configuration PDUs:

The software normally will not report adjacent cells' configuration messages. An exception exists when an adjacent Cell Configuration Message is sent **after** starting the software and before a Channel Stream Identifier is received. In this case, the software has not identified the channel stream and the current cell site identifier; so all Cell Configuration messages are reported.

If changing a parameter doesn't seem to affect software operation or test results:

A parameter change does not take effect until after the test is re-run. If you pause the software and change a parameter, you cannot press **Continue** to use the new parameter setting. You must go back to the Software Menu screen and select **Run Test** to use the new parameter value. The new parameter values are kept in memory until you directly change them again, or until you reload the test procedure from the memory card (resetting the parameters to their factory defaults). If you want to save your parameter changes for future use, refer to [“How to Save a Test Procedure” on page 118](#).

If Power or Sensitivity measurements seem inaccurate:

Both of these measurements are affected by cable and splitter/coupler losses. Perform test [“2. Cable/Diversity Splitter Loss Measurement” on page 54](#) and enter the values for the RX Cable and Diversity Splitter Loss ([page 79](#)) and the TX Cable Loss ([page 84](#)). Enter any receive or transmit path splitter or coupler losses in the RX Coupler/Splitter Loss parameter ([page 82](#)) and TX Coupler/Splitter Loss parameter [page 85](#).

If Sniffer testing doesn't work or is erratic:

Verify connections are as shown on the connect diagram displayed when the test is run. Cabling is different for the Sniffer Activation Time and Sniffer Threshold tests.

The MDBS Sniffer input is very sensitive. An attenuator (pad) between the Test Set's DUPLEX OUT connector and the Sniffer input may help minimize coupling and leakage signals. Most base stations will work with 12dB of attenuation (two 6dB pads are included with the CDPD Accessory kit). When measuring a high level signal on the Test Set's RF IN/OUT port, you must use a much greater amount of attenuation. Try using the fixed attenuator that is used in the cell site to attenuate the AMPS coupler signal (typically 50dB).

If the Forward Channel Control Flag, Sensitivity, or Busy Set Threshold tests do not pass or do not agree with each other:

The Busy/Idle and Decode Status flags and timing parameters were designed to work with all known makes of MDBSs. If your MDBS was not available at the time of manufacture, or has changed its reported Busy/Idle or Decode Status information from the time this software was written, you may require a different template. Call your Agilent Technologies Field Sales representative to determine if another template is available or could be created for your application.

Refer to the parameter descriptions for:

- “5. RX Busy Set Threshold (set-and-measure)” on page 77
- “6. RX Busy Set Threshold max level to test” on page 77
- “7. RX Busy Set Threshold min level to test” on page 77
- “8. RX Busy/Idle Flag template [0 to 10]” on page 78
- “10. RX Decode Stat timing [0=norm/1=relaxed]” on page 80
- “11. RX Decode Status Flag template [0 to 10]” on page 80
- “12. RX Fwd Channel Control Flag test level” on page 81
- “14. RX Sensitivity level (set-and-measure)” on page 81
- “15. RX Sensitivity max level to test” on page 82
- “16. RX Sensitivity min level to test” on page 82

If the message Change Ref Level, Input Port, or Attenuator (if using “hold”) appears:

This message may appear when a low RF level has been applied. Refer to the conditions in “If “No Signal Found” is displayed when attempting to test.” on page 35, if the message persists, and test results are not reported.

3 **Product Description**

This section briefly describes:

- What the software is and what it does.
- What is shipped with the Test Set.
- How to get software or firmware upgrades.
- Where to get additional Test System Information

What the CDPD Software is and What it Does

The CDPD software is an Agilent Technologies Instrument BASIC (IBASIC) program written to run on the Agilent Technologies E6381A internal IBASIC controller. The IBASIC controller controls all functions of the Agilent E6381A (except for volume and squelch), and also controls the internal CDPD hardware module. The software is shipped on a One Time Programmable (OTP) PCMCIA memory card.

The software provides parametric testing of Cellular Digital Packet Data Mobile Data Base Stations. Both receiver and transmitter measurements are available, as well as tests to verify many aspects of the base station control protocol, such as Packet Data Units (PDUs).

This software is not designed to test any other type of base station or mobile radio, such as TDMA or AMPS base stations. Refer to the *Agilent E6381A User's Guide* for information on how to test base stations with those formats.

Tests are selected by either using the default menus, or by creating your own test sequence from the available tests. Test system parameters are entered to conform the Test System to your needs, and specification limits are used to alert you to failing test results.

You can print test results to a printer, as well as save test result data in a file for later retrieval.

Procedures on the OTP PC Card

The OTP PC card contains the full CDPD program and supporting library and procedure files. The following procedures are included:

- CDPD - This is the main CDPD procedure that uses embedded menus to access each test.
- CABLOSS - This is TEST_02: Cable Loss Measurement. It is used to measure cable loss of connecting cables for the current test setup. These values are not stored on the card when the procedure is run (but will remain in internal RAM until a new procedure program is run). You must rerun this procedure if you change cables or measurement setup.
- CALS - This procedure performs all calibrations required by the Test Set for CDPD MDBS Cell Site testing.
- DEMO - The procedure automatically enables the Demonstration Mode to imitate testing an MDBS without any actual base station connections.
- SEQN - this is an example test sequence for MDBS testing.

What Is Shipped With the E6381A Option 003

When you ordered a E6381A, Option 003, you received the following items:

- ❑ E6381A equipped with Option 003.
 - Option 003 provides CDPD MDBS test capability
- ❑ CDPD MDBS Cell Site Test Software, Agilent Technologies part number E6381-61032, on a One Time Programmable PCMCIA memory card. A 1 MByte SRAM memory card is also included to allow you to store your own procedures and/or data.
- ❑ CDPD Mobile Data Base Station Software User's Guide (this manual).
- ❑ Accessory kit: Agilent Technologies part number 83204-61008. This accessory kit is used with both the E6381A and the Agilent Technologies 8921A Test Sets.

NOTE Not all parts on the kit are used with both Test Sets. The kit contains the following items:

Table 3-1 Accessory Kit Contents

Agilent Part Number	Qty	Description	Used with the Agilent E6381A	Used with the Agilent 8921A	Purpose
5182-4794	1	Cable Assy DB9(f) to DB9(f) 10 ft. Null	X		Connect E6381A Test Set to the laptop for data collection
08921-61038	1	RJ-11 to DB9(f) cable		X	Connect Agilent 8921A Test Set to laptop for data collection
0955-0698	2	6 dB Attenuator		X	Used for calibration and sniffer measurements
08921-61052	3	Cable: SMA(m), 10 ft.	X	X	Connect MDBS TX, RX, and sniffer to Test Set
0960-0053	2	50 Ohm termination	X	X	Used for calibration of RX path when using splitter

Table 3-1 Accessory Kit Contents

Agilent Part Number	Qty	Description	Used with the Agilent E6381A	Used with the Agilent 8921A	Purpose
1250-0781	1	BNC TEE: (f-m-f)	X	X	Splits Audio Out signal for use in Mod Input and Scope trigger input. Used during sniffer activation time test.
1250-1250	2	Adapter N(m) to SMA(f)	X	X	Used in TX, RX, sniffer, and calibration tests
1250-1700	2	Adapter BNC(m) to SMA(f)		X	Used in RX, sniffer, and calibration tests
1250-0080	1	Adapter BNC(f) to BNC(f)		X	Used for sniffer activation time test
1400-2157	5	Velcro Cable Wrap	X	X	Used to restrain cables
8120-1838	1	Cable: BNC(m), 1ft.	X	X	Used for sniffer activation time test and as jumper from CDPD mod out to mod in
8120-2582	1	Cable: BNC(m), 4ft.		X	Used for sniffer activation time test
83204-61011	2	Cable: SMA(m), 2ft.	X	X	Used to connect splitter to diversity receive ports on radio
0955-0168	1	SMA(f) power splitter	X	X	Used for RX diversity tests
1253-0374	1	Adapter SMA(f) to SMA(f)	X	X	Used to calibrate RX and TX cables

Software and Firmware Upgrades

The CDPD software may be revised in the future to provide added features. The firmware for the E6381A may also be enhanced after receiving your instrument. To determine if revisions have occurred, contact your local Agilent Technologies Sales Office for the latest available software and firmware revision numbers.

To Check Your Firmware, Software, and Test Set Code Revisions

To view firmware and software code revisions, select and run the test [“Software and Firmware Upgrades”](#) on page 46.

Additional Information

Programming Information

The Agilent Technologies E6381A's internal IBASIC controller can be used to perform automated tests, and can also be used to control other devices connected to the HP-IB. Refer to the Agilent Technologies 8935 Series E6380A CDMA Test Set and E6381A TDMA Test Set Programmer's Guide for information on programming the Test Set.

For detailed information on creating and editing Instrument BASIC programs, refer to the *Agilent Technologies Instrument BASIC Handbook*, part number E2083-90000.

A Product Note, *Using the IBASIC Programming Environment on the Test Set Family*, is also available to provides helpful information when programming the Test Set or connecting it to other devices. Order Agilent part number 5963-0046E

Agilent Technologies E6381A Operation

A description of all of the Agilent Technologies E6381A's features are provided in the *Agilent Technologies E6381A TDMA BST Reference Guide*. The manual explains the basic use of all of the Test Set's features and specifications.

Repair Information

The following manual is available to help you troubleshoot your Test Set:

- *Agilent Technologies E6381A Assembly Level Repair Guide*

4 Test Descriptions

This chapter describes what each test does and how it does it, including what parameters and additional equipment are used.

A setup diagram for the selected test is displayed when the test is run. The diagram indicates specific cable connections for that test, and usually contains other instructions specific to that test. It is important that you read and follow all instructions for each test.

After running the CDPD software, you should press the **PRESET** key to return the Test System to its default settings before making any manual Test Set measurements.

Test Descriptions

Tests can be accessed either of two ways:

- By loading and running the software as delivered, selecting the desired test(s) from the menus as they are displayed. After Transmitter, Receiver, PDU, or Sniffer measurements are started, the measurements repeat until Menu is selected by pressing the **k1 USER** key.
- By loading the software and then selecting the desired test(s) from the list of tests on the TESTS (Order of Tests) screen. Each selected test is run once, and can be aborted by pressing the **k1 USER** key (Next Test) to proceed to the next test. Using this method, you can also save a group of selected tests as a custom “procedure” file for later use (see “Creating Your Own Test Sequence” on page 100).

The test descriptions are listed in the order displayed on the TESTS (Order of Tests) screen.

To access the TESTS (Order of Tests) screen and view the tests:

1. Load the software, see “Step 1 - Load and Run the Software” on page 31.
2. Using the knob, position the cursor in front of the Seqn - Order of Tests field and then press the knob.
3. Move the cursor in front of the TEST_01 field and press the knob. The list of tests is displayed in a popup window.
4. Rotate the knob to move through the list of tests.

Connections for Transmitter and PDU Display Tests

For Transmitter tests, the only connection needed is a cable from the MDDBS Transmit port to the Test Set’s RF IN/OUT port.

Measurements can be made with the MDDBS in or out of service. If in service, a coupler or power splitter must be used to furnish the signal to the Test System. Do not use a simple “Tee” to split the signal. The coupler/splitter loss must be entered in the TX splitter/coupler loss parameter (“28. TX Splitter/Coupler loss” on page 85).

You must also enter any TX cable loss from the MDDBS to the Test System (see parameter “26. TX Cable Loss” on page 84), whether the MDDBS is in service or not. You can also use the Cable Loss routine to automatically calculate and enter the cable losses for you (see test “2. Cable/Diversity Splitter Loss Measurement” on page 54).

Connections for Receiver/Sniffer Tests

In addition to the Test System's cabling, all Receiver and Sniffer tests require that the MDDBS Receive/Sniffer port and Transmit port be connected to the Test System. The Receiver/Sniffer port is connected to the Test Set's DUPLEX OUT port, and the Transmit port is connected to the Test Set's RF IN/OUT port. As a Receiver test is being made, the MDDBS transmits a signal back to the test system to report received signal conditions.

Any splitter/coupler losses must be entered ("[19. RX Splitter/Coupler loss](#)" on page 82), as well as any cable loss from the Test Set's DUPLEX PORT to the MDDBS ("[9. RX Cable and Diversity Splitter loss](#)" on page 79).

"RX Input" and "TX Output" Cables in the Setup Diagrams

The connection diagrams shown for each test and calibration procedure use the terms "TX Output" and "RX Input" for the cables. These terms are used to identify specific cables you should use for each connection. The losses for these cables are measured and copied into the system parameters using the "[2. Cable/Diversity Splitter Loss Measurement](#)" on page 54. Once these values are entered, you should continue to use the same cables for receiver and transmitter measurements.

How Signals Are Acquired by the Test System

The Test System uses the spectrum analyzer in the Test Set to locate, and tune to, the strongest signal it finds. Once found, the software analyzes the signal to determine if it is in the cellular frequency band.

If the signal is in the cellular band, the software then analyzes the signal to determine if it is a CDPD base station. If the signal is not in the cellular band, the error message "No signal found" is displayed, and no measurements are attempted.

If the signal is in the cellular band, but is not a valid CDPD base station signal, the message "No signal found" is displayed, and no measurements are attempted.

If a valid CDPD signal was found, the software proceeds to make measurements on the signal.

If the signal is lost due to frequency hopping or a lost connection during reception, the message "Signal lost" is displayed. The software automatically attempts to re-acquire the signal and continue measurements if they are enabled.

1. GN Main Menu (accesses all tests)

This is the default test that is run if you load the “CDPD” procedure and run the software as shipped on the factory memory card. This test allows you to access all of the other tests (with the exception of test [22. Software/Firmware Revision Info](#)) Tests are accessed using a series of menus that organize the tests in the following groups:

- Transmitter Tests - to test transmitter RF characteristics
- Receiver Tests - to test all receiver characteristics
- System Tests - to test the base station's sniffer port and decode Packet Data Units (PDUs).
- Calibrations - to calibrate the Test Set and associated cables and splitters/couplers). Path losses, power measurement offsets, and GMSK modulation characteristics are calibrated.

After Transmitter, Receiver, PDU, or Sniffer measurements are started, the measurements repeat until Menu is selected by pressing the **k1 USER** key.

Parameters Used for This Test

All parameters may be used; depending on which tests are selected from the menus.

2. Cable/Diversity Splitter Loss Measurement

This test is used to calibrate and store cable and splitter loss measurements for the test equipment you are using. If desired, you can change the frequency range over which the loss is calibrated by entering new stop and start frequencies.

After measuring the loss, the software prompts you to select how you want the value stored; as a receiver cable and diversity splitter loss or as a transmitter cable loss. The value is then automatically entered into the appropriate parameter. Since the value is entered as a parameter, it is saved if the procedure is saved. However, if you load a different procedure, the cable losses associated with the new procedure will be used. (see parameter “[9. RX Cable and Diversity Splitter loss](#)” on page [79](#) and parameter “[26. TX Cable Loss](#)” on page [84](#).)

Pay close attention to the connection diagram for this test; the connections shown are not exactly as they appear on the Test Set.

NOTE

Label your cables: TX & RX

After calibrating your cables, you should label the cables for future use to ensure that the entered cable losses continue to correspond to the cables being used.

What Happens During this Test

1. A calibrated signal is sent out the DUPLEX OUT port, through a short 50 Ω cable and then back to the Test Set's ANT IN port.
2. The level at the ANT IN port is compared to the level out the DUPLEX OUT port, and the difference is automatically entered into Cable Loss Measurement algorithm.
3. The cable (and splitter if used) to be calibrated is then inserted between one end of the calibration cable and either the ANT IN or DUPLEX OUT port.
4. The level at the ANT IN port is measured again to determine the loss value of the additional cable.

Parameters Used for This Test

- [parameter 9. RX Cable and Diversity Splitter loss](#)
- [parameter 26. TX Cable Loss](#)

Additional Equipment Needed

- A short 50 Ω cable.
- The cable(s) you want to calibrate.

3. Power Measurement Calibration (Agilent Technologies E6381A)

Refer to test “6. TX Test (all)” on page 57 for additional information on the TX Channel Power and TX Power measurements. Which measurement is displayed when tests are run depends on the input port used (see parameter “4. GN Testset Input Port [0=RF IN/1=ANT IN]” on page 77). Power calibration factors are not saved as part of procedure files, and are therefore not affected by loading a new procedure.

To provide measurement accuracy, TX Channel Power must be calibrated the first time transmitter tests are run. This test creates a calibrated signal and measures its power level with a Digital Signal Processor in the Test Set to generate and store calibration factors. You should re-calibrate whenever the operating temperature of the Test Set is changed several degrees.

TX Power uses the Test Set’s internal power meter to measure transmitter power, and is automatically calibrated each time the software is run.

Operating Considerations

CAUTION

CAUTION: disconnect your transmitter first!

Always disconnect your transmitter before connecting any calibration cables for this test. Also, always disconnect calibration cables at the end of the test before connecting your transmitter.

- The Test Set should be at normal operating temperature before running this test.

Parameters Used for This Test

- [parameter 9. RX Cable and Diversity Splitter loss](#)

Additional Equipment Needed

- A short calibration cable.

4. GMSK Deviation Calibration (Agilent Technologies E6381A)

The Test Set's RF Generator provides the reverse channel signal used for receiver testing. The Test Set creates the modulating signal for the RF Generator. This test establishes the modulating signal level from the Test Set required to generate the correct 0.5 Gaussian Minimum Shift Keying (GMSK) signal. This test is automatically performed when required.

GMSK calibration factors are not saved as part of procedure files, and are therefore not affected by loading a new procedure.

This test does not require any optional equipment or cabling, and is not affected by any Parameter settings.

5. Center Frequency Calibration (Agilent Technologies E6381A)

This procedure removes any RF Generator DCFM offset caused by the modulating signal from the Test Set. This test is automatically performed when required.

This test does not require any optional equipment or cabling, and is not affected by any Parameter settings.

6. TX Test (all)

All transmitter measurements are returned when this test is performed (in fact, they can not be run individually). The Test Set contains a high performance Digital Signal Processor (DSP) that measures several CDPD parameters at one time, eliminating the need for separate measurement routines. Only one measurement connection setup is needed, and is displayed when the test is run.

Refer to the connection diagrams in the Getting Started chapter for more information on how transmitter measurements are made.

The following measurement values are displayed:

Frequency Error

This value is displayed both as an absolute value (in Hz) and as a relative value (in ppm).

When displayed in Hz, this is the difference (in frequency) between what the forward channel frequency should be and what the Test System measured. When displayed this way, the error is not affected by the center frequency being measured. A 10 Hz error at 950 MHz or 800 MHz mean the same thing; the signal is 10 Hz away from the expected center frequency.

When displayed in ppm, this is variance from what the channel frequency should be relative to the measured channel frequency. For example; a 1ppm variance at 800 MHz would be 800 Hz, but a 1ppm variance at 900 MHz would be 900 Hz. Therefore, the greater the frequency being measured, the greater the frequency difference can be and still maintain the same 1 ppm error.

Modulation Index

This is the modulation accuracy measurement for the 0.5 GMSK modulation used for CDPD. A perfect modulation index is 0.500; the CDPD standards allow a tolerance of $\pm 1\%$.

TX Power

This is the total power of all signals at the Test Set's RF IN/OUT port, from 400 kHz to 1 GHz. This measurement is only displayed if parameter 4. GN Testset Input Port [0=RF IN/1=ANT IN], is set to 0. *When measuring signals >200 mW, you must use this setting, and the connections indicated when the test is run, to prevent instrument damage.*

TX Channel Power

This is the power in a 30 kHz bandwidth, centered around the center frequency of the channel being measured. This measurement is only displayed if parameter 4. GN Testset Input Port [0=RF IN/1=ANT IN], is set to 1. *Use this setting only when transmitter power is ≤ 200 mW.*

Adjacent Channel Power, First Alternate Channel Power, Second Alternate Channel Power

These tests measure the amount of power present in 30 kHz bandwidth centered around a frequency 30 kHz (1 channel), 60 kHz (2 channels), or 90 kHz (3 channels) offset from the transmitted channel.

Incidental FM

This is the RMS level of instantaneous frequency error when the modulated signal is at its peak deviation for more than two consecutive 1's or two consecutive 0's.

Parameters Used for This Test

- parameter 1. GN Signals Present [0=single,1=many]
- parameter 2. GN sound BEEP in menu [0=no/1=yes]
- parameter 3. GN System [1=A system, 2=B sys, 0=both]
- parameter 4. GN Testset Input Port [0=RF IN/1=ANT IN]
- parameter 26. TX Cable Loss
- parameter 27. TX Channel Power
- parameter 28. TX Splitter/Coupler loss

7. RX Forward Channel Control Flag

This test verifies that the MDBS Forward Control Flag bits are correctly set and reset in the presence of reverse channel bursts. The Control Flag is a series of bits that report the current Busy/Idle and Decode Status of the MDBS. The bursted GMSK signal from the DUPLEX OUT port is connected to the MDBS receiver port(s).

The following message is displayed if the Control Flag is properly set. RX Fwd Channel Control Flag tested at xx dBm (where xx represents the level used during the test).

If the test fails, the decoded Decode Status (DS) and Busy/Idle (BI) bits are displayed. The bit(s) not properly encoded are marked with the ^ character under them, followed by an “F” (fail) on the top line (see [Figure 4-1](#)). If the indicated failed bits are on the DS: line, try changing Parameter 11- Decode Status Flag Template, or Parameter 10 - RX Decode Stat timing, and rerun the test. If the indicated failed bits are on the BI: line, try changing Parameter 8 - RX Busy/Idle Flag Template, and rerun the test.

Figure 4-1 Example of Failing Decode Status and Bust/Idle Status Flag Bits

```

BI: 11111111111111111111111111111111      F
      ^
      AAAAAAAAAAAAAA
DS: 11111111111111111111111111111111
      AAAAAAAAAAAAAA
Points passed=0: Points failed=1

```

Parameters Used for This Test

- parameter 4. GN Testset Input Port [0=RF IN/1=ANT IN]
- parameter 8. RX Busy/Idle Flag template [0 to 10]
- parameter 9. RX Busy Set Threshold (iterative)
- parameter 10. RX Decode Stat timing [0=norm/1=relaxed]
- parameter 11. RX Decode Status Flag template [0 to 10]
- parameter 12. RX Fwd Channel Control Flag test level
- parameter 13. RX LNA Gain
- parameter 19. RX Splitter/Coupler loss

8. RX Busy Set Threshold (set-and-measure)

This test verifies that the transmitter's Busy/Idle Flag is set and cleared properly when a specified level of bursted reverse channel signal is fed into the receiver.

The measurement returns the value of the instantaneous MDDBS Busy/Set threshold. Some MDDBSs may have instantaneous MDDBS busy/set thresholds which are different from the network or local set level for the BS threshold (the number that has been entered or desired). Refer to the test, "[10. RX Busy Set Threshold \[w/training\]](#)" on [page 62](#). You should verify that the instantaneous values have been properly trained if the returned values differ substantially from what you expect.

Parameters Used for This Test

- [parameter 4. GN Testset Input Port \[0=RF IN/1=ANT IN\]](#)
- [parameter 5. RX Busy Set Threshold \(set-and-measure\)](#)
- [parameter 8. RX Busy/Idle Flag template \[0 to 10\]](#)
- [parameter 9. RX Cable and Diversity Splitter loss](#)
- [parameter 10. RX Decode Stat timing \[0=norm/1=relaxed\]](#)
- [parameter 11. RX Decode Status Flag template \[0 to 10\]](#)
- [parameter 13. RX LNA Gain](#)
- [parameter 19. RX Splitter/Coupler loss](#)

9. RX Busy Set Threshold (iterative)

This test varies the signal level into the receiver to determine the exact level needed to set the transmitter's Busy/Idle Flag to Busy. Parameters 6 and 7 set the maximum and minimum signal levels to use at the start of the test. Set these parameters to reduce the range of measurement required.

The measurement returns the value of the instantaneous MDBS Busy/Set threshold. Some MDBSs may have instantaneous MDBS busy/set thresholds which are different from the network or local set level for the BS threshold (the number that has been entered or desired). Refer to the test, "[10. RX Busy Set Threshold \[w/training\]](#)" on [page 62](#). You should verify that the instantaneous values have been properly trained if the returned values differ substantially from what you expect.

Parameters Used for This Test

- [parameter 4](#). GN Testset Input Port [0=RF IN/1=ANT IN]
- [parameter 6](#). RX Busy Set Threshold max level to test
- [parameter 7](#). RX Busy Set Threshold min level to test
- [parameter 8](#). RX Busy/Idle Flag template [0 to 10]
- [parameter 9](#). RX Cable and Diversity Splitter loss
- [parameter 10](#). RX Decode Stat timing [0=norm/1=relaxed]
- [parameter 11](#). RX Decode Status Flag template [0 to 10]
- [parameter 13](#). RX LNA Gain
- [parameter 19](#). RX Splitter/Coupler loss

10. RX Busy Set Threshold [w/training]

This test is used to test the busy/set threshold on MDBSs that utilize dynamic threshold setting (training). The upper limit of parameter “2. RX Sensitivity (iterative method)” on page 92 is used as the starting (high) level that is applied during training. As training occurs, the number of bursts, applied level, and busy/idle status are reported.

Parameters Used for This Test

- parameter 4. GN Testset Input Port [0=RF IN/1=ANT IN]
- parameter 6. RX Busy Set Threshold max level to test
- parameter 7. RX Busy Set Threshold min level to test
- parameter 8. RX Busy/Idle Flag template [0 to 10]
- parameter 9. RX Cable and Diversity Splitter loss
- parameter 10. RX Decode Stat timing [0=norm/1=relaxed]
- parameter 11. RX Decode Status Flag template [0 to 10]
- parameter 13. RX LNA Gain
- parameter 19. RX Splitter/Coupler loss

11. RX Sensitivity (set-and measure)

This test verifies that the Block Error Rate for the received signal is $\leq 5\%$ at a specified signal level.

The RX Sensitivity measurement result depends on the configured Busy/Idle Threshold of the base station under test. Set the configured Busy/Idle Threshold value of the base station below the level of the sensitivity you expect to measure.

Parameters Used for This Test

- parameter 4. GN Testset Input Port [0=RF IN/1=ANT IN]
- parameter 9. RX Cable and Diversity Splitter loss
- parameter 13. RX LNA Gain
- parameter 14. RX Sensitivity level (set-and-measure)
- parameter 17. RX Sensitivity test frequency offset
- parameter 18. RX Sensitivity test MAX_BLOCK [64 max]
- parameter 19. RX Splitter/Coupler loss

12. RX Sensitivity (set/meas, +/- 3 kHz)

This test verifies that the Block Error Rate (BER) for the received signal is $\leq 5\%$ at a specified signal level, measured at the center frequency and at ± 3 kHz offsets.

The signal from the DUPLEX OUT port into the receiver is adjusted to 3 kHz above the center frequency for one BER measurement, adjusted to the center frequency for a another BER measurement, and then adjusted to 3 kHz below the center frequency for another BER measurement.

The RX Sensitivity measurement result depends on the configured Busy/Idle Threshold of the base station under test. Set the configured Busy/Idle Threshold value of the base station below the level of the sensitivity you expect to measure.

Parameters Used for This Test

- parameter 4. GN Testset Input Port [0=RF IN/1=ANT IN]
- parameter 9. RX Cable and Diversity Splitter loss
- parameter 13. RX LNA Gain
- parameter 14. RX Sensitivity level (set-and-measure)
- parameter 18. RX Sensitivity test MAX_BLOCK [64 max]
- parameter 19. RX Splitter/Coupler loss

13. RX Sensitivity (iterative)

This test determines the minimum received signal level equivalent to one causing a Block Error Rate of $\leq 5\%$.

The RX Sensitivity measurement result depends on the configured Busy/Idle Threshold of the base station under test. Set the configured Busy/Idle Threshold value of the base station below the level of the sensitivity you expect to measure.

Parameters Used for This Test

- parameter 4. GN Testset Input Port [0=RF IN/1=ANT IN]
- parameter 9. RX Cable and Diversity Splitter loss
- parameter 13. RX LNA Gain
- parameter 15. RX Sensitivity max level to test
- parameter 16. RX Sensitivity min level to test
- parameter 17. RX Sensitivity test frequency offset
- parameter 18. RX Sensitivity test MAX_BLOCK [64 max]
- parameter 19. RX Splitter/Coupler loss

14. Sniffer Threshold (set-and-measure)

This test verifies that the MDBS stops transmitting when a specified level of signal is input to the MDBS Sniffer Port.

Parameters Used for This Test

- parameter 4. GN Testset Input Port [0=RF IN/1=ANT IN]
- parameter 9. RX Cable and Diversity Splitter loss
- parameter 19. RX Splitter/Coupler loss
- parameter 22. Sniffer Port Pad (Optional)
- parameter 23. Sniffer Sensitivity (set-and-measure)
- parameter 26. TX Cable Loss
- parameter 28. TX Splitter/Coupler loss

15. Sniffer Threshold (iterative)

This test varies the level into the Sniffer Port to determine the level required to cause the MDBS to stop transmitting.

Parameter Used for This Test

- parameter 4. GN Testset Input Port [0=RF IN/1=ANT IN]
- parameter 9. RX Cable and Diversity Splitter loss
- parameter 19. RX Splitter/Coupler loss
- parameter 22. Sniffer Port Pad (Optional)
- parameter 24. Sniffer Sensitivity max level to test
- parameter 25. Sniffer Sensitivity min level to test
- parameter 26. TX Cable Loss
- parameter 28. TX Splitter/Coupler loss

16. Sniffer Activation Time

This test measures the time it takes the transmitter to stop transmitting after the Sniffer Port receives a signal of a specified level.

Parameter Used for This Test

- parameter 4. GN Testset Input Port [0=RF IN/1=ANT IN]
- parameter 9. RX Cable and Diversity Splitter loss
- parameter 19. RX Splitter/Coupler loss
- parameter 21. Sniffer Injection Level (to test timing)
- parameter 22. Sniffer Port Pad (Optional)
- parameter 26. TX Cable Loss
- parameter 28. TX Splitter/Coupler loss

17. Display CSI PDU

This test decodes and displays the Channel Stream Identification (CSI) Protocol Data Units (PDU) information from the MDBS transmitter. This data tells the M-ES (Mobile-End Station) which MDBS it is communicating with, and reports a number of additional CDPD system parameters associated with that MDBS.

The Channel Stream Identifier (CSI), Channel number, Group Color Code, and the time when the measurements were made, are all displayed above the measurement area. By pressing the **k1 USER** key, you can select the next CSI in your system to analyze.

Parameters Used for This Test

- [parameter 4. GN Testset Input Port \[0=RF IN/1=ANT IN\]](#)

Reported Information

The following information is reported each time a CSI PDU is received:

Protocol Version

This is the version or Radio Resource Management protocol being used.

Dedicated Channel Flag

This indicates whether the channel can be used for frequency hopping. A value of 1 indicates that the current RF channel is dedicated for CDPD use (non-hopping). A value of 0 indicates that the channel may be used in a frequency hopping CDPD system.

Channel Stream Identifier

This is a number between 1 and 63 (inclusive) that identifies the individual MDBS in a cell.

SPNI

The Service Provider Network Identifier (SPNI) identifies the CDPD service provider for that cell. Each service provider has a single, unique identification number that is used to identify all of their cells.

Cell Number

The cell number identifies which cell/sector is being accessed in that service provider's network.

Service Provider Identifier

The Service Provider Identifier (SPI) identifies a facilities-based cellular service provider that is licensed to provide CDPD services. This number is unique to each service provider.

Wide Area Service Identifier

A Wide Area Service Identifier (WASI) identifies a network of service providers that have a cooperative agreement to provide CDPD service over a large geographic area.

Power Product

The Power Product is a value transmitted by the MDBS to the M-ES. The M-ES uses this, along with the received signal strength of the forward channel and the maximum allowed power level, to determine how much power to transmit to provide an adequate signal to the MDBS receiver on the reverse channel.

The Power Product will vary between cells to adjust for the size of the cell area, the MDBS transmitted power, and geographic factors affecting signal strength.

Max Power Level

This value tells the M-ES the maximum transmit power level it may use. The value corresponds to the levels in the following table.

Table 4-1 M-ES Max Power Level Setting (from CSI PDU)

M-ES Maximum Power Level	Maximum ERP for M-ES (dBW)
0	6
1	2
2	-2
3	-6
4	-10
5	-14
6	-18
7	-22
8	-22
9	-22
10	-22

18. Display CC PDU

This test decodes and displays the Cell Configuration (CC) Protocol Data Units (PDU) information from the MDBS transmitter. The CC parameters provide information to the M-ESs to allow channel hopping and to transfer between cells.

The Channel Stream Identifier (CSI), Channel number, Group Color Code, and the time when the measurements were made, are all displayed above the measurement area. By pressing the **k1 USER** key, you can select the next CSI in your system to analyze.

Parameters Used for This Test

- [parameter 4. GN Testset Input Port \[0=RF IN/1=ANT IN\]\]](#)

Reported Information

The following information is reported.

Cell Number

This number identifies the cell where the MDBS is located.

Area Color Code

This is the Area Color Code for the adjacent cell indicated in the Cell ID portion of the returned Service Provider Network Identifier (SPNI) data. This information allows the M-ES to determine whether that cell is serviced by the same MD-IS as the current cell.

Active Ch(annel) Streams

This is the number of currently active channels in the specified cell. A channel may be active, but be preempted by non-CDPD use at the current time. A value of 0 indicates that CDPD is not active at that cell; a value of 7 indicates that *at least* 7 channels are active.

Reference Channel

This is the channel number of the reference channel for that cell. The reference channel's signal level is used by the M-ES to determine the best cell to transfer to when moving from one cell to another. This value will be in the range of 1 to 1023.

ERP Delta

This is the difference in Effective Radiated Power between the Reference Channel and the CDPD RF channels in the Channel List. The number is a signed 2's-complement value in dB expressed as:
ERP Delta (dB) = Reference Channel (dBW) - CDPD Channel (dBW)

RSSI Bias

This value allows the service provider to alter when an M-ES transfers its connection to an adjacent cell. By offsetting (biasing) the Receiver Signal Strength Indicator value, the mobile will transfer to another cell earlier or later than it normally would with an unbiased RSSI measurement. The number is a signed 2's-complement value in dB, and is derived using the following channel powers:

$$\text{RSSI Bias (dB)} = \text{Adjacent Cell Channel (dBW)} - \text{Current Channel (dBW)}$$

Power Product

See [“Power Product” on page 67](#)

Max Power Level

See [“Max Power Level” on page 67](#)

RF Channels

This is a list of all RF channels in that cell that can be used for CDPD. Channels marked with a “D”, such as 107D, are dedicated CDPD channels.

SPNI

See [“SPNI” on page 66](#)

Face

This value tells if the associated cell is a facing sector of the current cell. The value is set to 1 for facing cells.

19. Display CQP PDU

This test decodes and displays the Channel Quality (CQ) Protocol Data Units (PDU) information from the MDBS transmitter. This information conveys Quality Assessment parameters associated with the current channel.

The Channel Stream Identifier (CSI), Channel number, Group Color Code, and the time when the measurements were made, are all displayed above the measurement area. By pressing the **k1 USER** key, you can select the next CSI (MDBS) in your system to analyze.

Parameters Used for This Test

- [parameter 4. GN Testset Input Port \[0=RF IN/1=ANT IN\]](#)

Reported Information

The following information is reported.

RSSI Hysteresis

This is the Received Signal Strength Indicator (RSSI) hysteresis value for the current channel. This value is used to help prevent the M-ES from jumping back and forth between cells in an area bordering two strong cells. This value is compared to the RSSI of a candidate alternate channel when deciding when to change channels and which channel to go to. It is a signed value, expressed in dB.

RSSI Scan Time

This the maximum time (in seconds) that may elapse before the M-ES Radio Resource Management Entity (RRME) must initiate the channel scan procedure. Channel scanning is used to determine the best cell to use, based on the RSSI of the channels from adjacent cells. A value of 0 means the RSSI Scan Time function is disabled.

RSSI Scan Delta

This is the change in average RSSI that shall cause the M-ES Radio Resource Management Entity (RRME) to initiate the channel scan procedure. A value of 0 means the RSSI Scan Threshold function is disabled.

RSSI Average Time

This value (in seconds) defines how long the average RSSI of the MDBS must exceed the RSSI Scan Delta value before the M-ES RRME takes action to change channels.

BLER Threshold

This is the Block Error Rate (BLER) threshold for the current channel (expressed as a percent). High values of BLER threshold cause the M-ESs to use the BLER measurement to detect catastrophic channel conditions. Low values may cause M-ESs to initiate adjacent channel scans based on intermittent channel degradation.

BLER Average Time

This value sets the length of time (in seconds) over which the Block Error Rate measurement is averaged.

20. Display CAP PDU

This test decodes and displays Channel Access Parameters (CAP) Protocol Data Units (PDU) information from the MDDBS transmitter.

The Channel Stream Identifier (CSI), Channel number, Group Color Code, and the time when the measurements were made, are all displayed above the measurement area. By pressing the **k1 USER** key, you can select the next CSI (MDDBS) in your system to analyze.

Parameters Used for This Test

- [parameter 4. GN Testset Input Port \[0=RF IN/1=ANT IN\]](#)

Reported Information

The following information is reported.

Max TX Attempts

This is the maximum number of times an M-ES may attempt to obtain CDPD service with that MDDBS. A transmission attempt is either the sensing of the Busy/Idle flag, or the actual transmission of a burst. If the maximum number of transmission attempts is exceeded, the M-ES shall abort the transmission attempt.

Min Idle Time

After the M-ES has entered the idle state, this is the minimum amount of time (in microslots) that the M-ES must wait before attempting to send a new reverse channel transmission.

Max Blocks

This is the maximum number of blocks that a full-duplex M-ES can send before entering the DECODE WAIT state to see if the MDDBS received correctable data.

Max Entrance Delay

After finding that the forward channel Busy/Idle status is busy, this is the maximum amount of time (in microslots) that the M-ES must wait before checking the status again. A counter is incremented each time the Busy/Idle status is checked, and is compared to the Max_TX_Attempts setting (see “Max TX Attempts” on page 71).

Min Count

When in the BACKOFF state, the M-ES COUNT value is incremented each time the Busy/Idle flag is checked and found to be set to Busy. This is the starting COUNT value when a new count is started.

Max Count

When in the BACKOFF state, the M-ES COUNT value is incremented each time the Busy/Idle flag is checked and found to be set to Busy. This is the maximum COUNT value allowed before a new count is started.

21. Display All PDUs

This test contains all of the previously described PDU tests. Data is presented in the order it is received. If needed, use data collection to record the data as it is decoded for each PDU.

Parameters Used for This Test

- [parameter 4. GN Testset Input Port \[0=RF IN/1=ANT IN\]](#)

22. Software/Firmware Revision Info

This test displays several types of information about the software, firmware, and hardware of your test system. This “test” is not available using the default menu selection screens; you must select it from the TESTS (Order of Tests) screen.

Two screens are displayed. The first screen briefly displays the part number, copyright information, and software revision number:

The second screen displays hardware and firmware information for your test system.

5 **Test Parameters**

This chapter explains what each test parameter does and how to change them to meet your test system requirements.

Test Parameters Descriptions

Test parameters allow you to change test conditions to match your base station and test system situation. These changes alter how the tests are performed and how the measurement values are calculated. Some parameters are used by more than one test. Refer to [Chapter 4](#), “[Test Descriptions](#),” on [page 49](#) to see which parameters are used by each test.

- GN parameters affect general operation (such as whether or not you want to hear a beep whenever a new menu is displayed).
- RX parameters specify receiver test conditions (such as maximum signal level to use when testing sensitivity).
- TX parameters specify transmitter test conditions (such as cable loss between the base station and Test Set.)

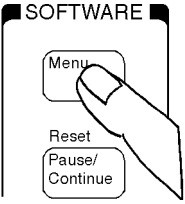
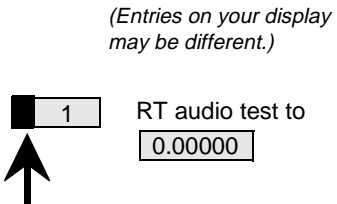
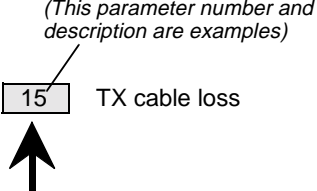
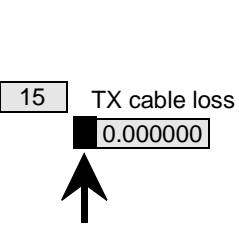
Editing Parameters

To access and edit the parameter values:

1. Load the CDPD software, but do not run it. See “[Step 1 - Load and Run the Software](#)” on [page 31](#).
2. Using the cursor, select the `Parm - Test Parameters` field in the lower part of the TESTS (Main Menu) screen.
3. Use the cursor to select the parameter you want to change, then use the DATA keys to enter the new value.

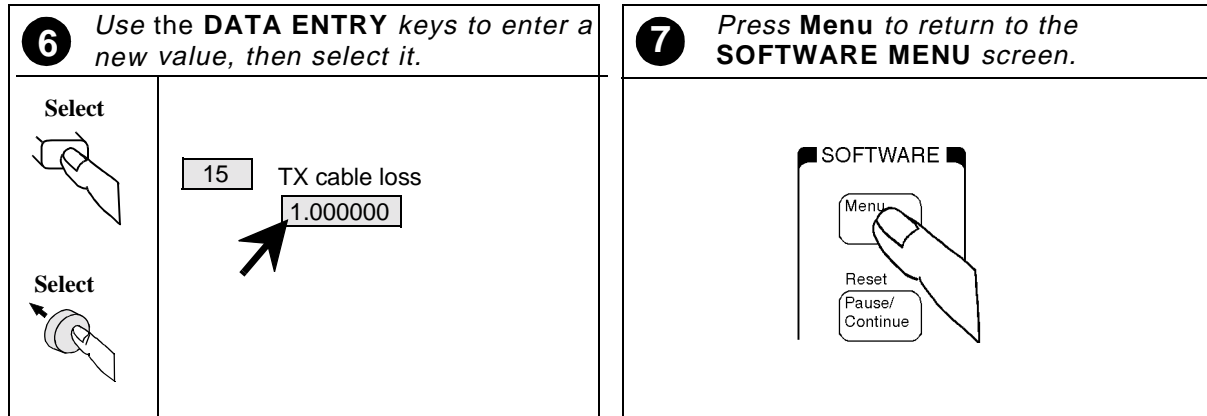
The following figures illustrate this procedure:

Figure 5-1

<p>1 Press the Menu key to display the SOFTWARE MENU screen.</p> <p><i>IF you're in IBASIC, press Shift, Pause/Continue before pressing Menu.</i></p> 	<p>2 Position the cursor at Parm Test Parameters... and select it.</p> <table border="1" data-bbox="987 394 1321 533"> <tr> <td>Freq</td> <td>Channel Information</td> </tr> <tr> <td>Parm</td> <td>Test Parameters</td> </tr> <tr> <td>Seqn</td> <td>Order of Tests</td> </tr> <tr> <td>Spec</td> <td>Pass Fail Limits</td> </tr> <tr> <td>Proc</td> <td>Save/Delete Procedure</td> </tr> </table>	Freq	Channel Information	Parm	Test Parameters	Seqn	Order of Tests	Spec	Pass Fail Limits	Proc	Save/Delete Procedure
Freq	Channel Information										
Parm	Test Parameters										
Seqn	Order of Tests										
Spec	Pass Fail Limits										
Proc	Save/Delete Procedure										
<p>The TESTS (Test Parameters) screen is now present on your display.</p>	<p>3 Position the cursor at Parm # field and select it.</p> <p><i>(Entries on your display may be different.)</i></p> 										
<p>4 Scroll to the Parm # to be changed and select it.</p> <p><i>(This parameter number and description are examples)</i></p> 	<p>5 Position the cursor at Value field and select it.</p> 										

Continue on next page

Figure 5-2



Parameter Limits When the software is run, it examines the parameter settings to make sure they make sense before testing begins. For example; it doesn't make sense try to test a radio if you have an entered RX Cable Loss of 5,000 dB! Limits for each parameter are listed. The software will let you enter an incorrect value, but will let you know it is out of limits when you go to test.

Default Values To determine default parameter values, load the "CDPD" procedure into the Test Set and read the values on the TESTS (Test Parameters) screen.

1. GN Signals Present [0=single,1=many]

NOTE This parameter is currently not used.

Limits: 0 is the only valid entry.

2. GN sound BEEP in menu [0=no/1=yes]

Enter 0 to disable the audible beep that occurs whenever a new menu is displayed.

Enter 1 to enable the new menu beep.

Limits: 0 and 1 are the only valid entries.

3. GN System [1=A system, 2=B sys, 0=both]

NOTE This parameter is currently not used.

Limits: 0 is the only valid entry.

4. GN Testset Input Port [0=RF IN/1=ANT IN]

Enter 0 to use the RF IN port any time you are measuring high level signals (>200 mW).

CAUTION

over-power damage

To prevent damaging the Test Set, the ANT IN port should only be used for transmitter measurements that are (≤ 200 mW).

Limits: 0 and 1 are the only valid entries.

5. RX Busy Set Threshold (set-and-measure)

Enter the specified signal level into the receiver that should set the busy/idle flag.

Limits: (lower) -137 dBm, (upper) +3 dBm

6. RX Busy Set Threshold max level to test

Enter the highest signal level to use for the iterative Busy Set Threshold test. This level should *always* cause the transmitter's Busy/Idle flag to get set to busy. This value should be set to a higher ("stronger") signal level than specified in parameter 7.

Limits: (lower) -137 dBm, (upper) +3 dBm

7. RX Busy Set Threshold min level to test

Enter the lowest signal level to use for the iterative Busy Set Threshold test. This level should *always* cause the transmitter's busy/idle flag to get set to idle. This value should be set to a lower ("weaker") signal level than specified in parameter 6.

Limits: (lower) -137 dBm, (upper) +3 dBm

8. RX Busy/Idle Flag template [0 to 10]

Select a template from the following table that corresponds to the bit pattern your MDBS produces when reporting the Busy/Idle flags. Manufacturer-specific patterns were known to work at the time this information was published, but may change as manufacturers change their software.

Table 5-1 Busy/Idle Flag Templates

Template #	Bit Pattern (X=don't care)
0 (Standard except transitions)	XX000000000000XX11111111111111
1, 3-7 (Standard, Tellabs)	1000000000000011111111111111
2 (Motorola HD-II)	1X00000000000011111111111111
8 (Relaxed)	XXXX0000XXXXXXXXXXXXXXXXXXXX

Limits: (lower) 0, (upper) 10

9. RX Cable and Diversity Splitter loss

Enter the amount of signal loss through the cable connecting the Test Set's DUPLEX OUT port to the MDBS receiver's input(s). If a signal splitter is used for diversity testing using both RX inputs, combine the splitter's loss and cable losses and enter the total.

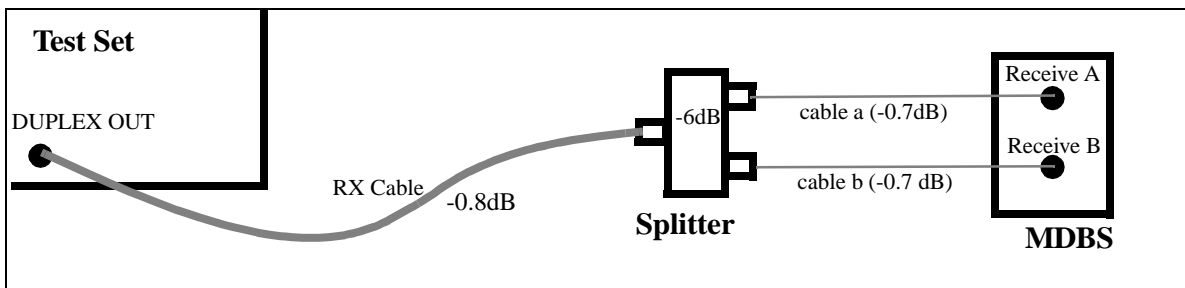
Limits: (lower) 0, (upper) 20

The example in Figure 5-3 on page 79 indicates a typical test setup, where the loss is the combination of the RX Cable (-0.8dB), the Splitter (-6dB), and the splitter cables (-0.7dB) for a total loss of 7.5dB.

This value is automatically entered when the Cable Loss Measurement calibration procedure is run and you save the result as the `RX Loss`. You may also manually enter the loss value.

For any other losses that might occur in your receiver testing setup, such as the insertion of couplers or additional cables, refer to "19. RX Splitter/Coupler loss" on page 82.

Figure 5-3 Entering RX Cable and Diversity Splitter Loss for Receiver Tests



10. RX Decode Stat timing [0=norm/1=relaxed]

Select the numbers of Decode Status errors to be allowed when making receiver measurements.

- 0=norm (no errors allowed).
- 1=relaxed (up to 2 errors allowed out of 5 status bits). Helpful for Motorola HD-II.

Limits: 0 and 1 are the only valid entries.

11. RX Decode Status Flag template [0 to 10]

Select a template from the following table that corresponds to the bit pattern your MDBS produces when reporting the Decode Status flag bits. These manufacturer-specific patterns were known to work at the time this information was published, but may change as manufacturers change their software.

Table 5-2 Status Flag Templates

Template #	Bit Pattern (X=don't care)
0 (Standard except transitions)	111111111XX000000000XX11111111
1 (As per CDPD Specifications)	11111111110000000000111111111
2 (Non-standard, allows most MDBSs to decode without errors.)	11111111110000000000XXX111111
3 (For ADC MDBS)	11111111110000000000000111111
4 (Hughes & Tellabs MDBS)	11111111110000000000000111111
5 (Motorola HD-II MDBS)	111111111110000000000X1111111
6 (Non-standard, allows most MDBSs to decode without errors. (updated))	111111111XX000000000XXX111111
7 Tellabs (updated)	11111111110000000000000111111
8-10 (Same as template #1 at this time.)	11111111110000000000111111111

Limits: (lower) 0, (upper) 10

12. RX Fwd Channel Control Flag test level

Enter the reverse (receive) channel signal level to use when using a bursted signal to test the correct operation of the forward channel control flag.

Limits: (lower) -137 dBm, (upper) +3 dBm

13. RX LNA Gain

Enter any Low Noise Amplifier (LNA) gain normally present between the receive antenna and MDDBS receiver's main and diversity inputs. This causes the level out of the DUPLEX OUT port, and the reported receiver sensitivity level, to be offset by that value. (Default is 0 dB).

This parameter compensates for an LNA that is *not used* during the receiver tests, but is used in normal operation. Therefore, the returned measurement is not really the sensitivity of the MDDBS receiver at its inputs; it is the estimated sensitivity of the receiver path through the LNA and into the MDDBS.

Depending on the noise figure and gain of the LNA, the test can produce a slightly different measurement result for sensitivity tests than if you actually measured sensitivity through the LNA.

Note: The Pass/Fail limits for all receiver tests should be set to reflect the value entered. For example: if the manufacturer's minimum sensitivity limit is -78dBm at the MDDBS receiver port, and you normally use an LNA with 20dB of gain, you should set the Pass/Fail limit to -98dBm to compensate.

Limits: (upper) -20 dB, (lower) +30 dB

14. RX Sensitivity level (set-and-measure)

Enter the receiver's specified sensitivity level for a Block Error Rate of $\leq 5\%$. This sets the RF level from the Test Set's DUPLEX OUT port into the receiver (cable and splitter/coupler losses are automatically corrected for using the values entered into parameters 9 and 18).

Limits: (lower) -137 dBm, (upper) +3 dBm

Default Values:

To determine default parameter values, load the "CDPD" procedure into the Test Set and read the values on the TESTS (Test Parameters) Screen.

15. RX Sensitivity max level to test

Enter the maximum signal to use when making an iterative RX Sensitivity test. This level should *always* result in a block error rate of <5%. The level should be set higher (“stronger”) than the level specified in parameter 15.

Limits: (lower) -137 dBm, (upper) +3 dBm

16. RX Sensitivity min level to test

Enter the minimum signal to use when making an iterative RX Sensitivity test. This level should *always* result in a block error rate of >5%. The level should be set lower (“weaker”) than the level specified in parameter 14.

Limits: (lower) -137 dBm, (upper) +3 dBm

17. RX Sensitivity test frequency offset

Enter the frequency offset used to verify receiver sensitivity (CDPD System Specifications, part 408, section 7.1.2, specifies a 3kHz offset). This parameter does not change the center frequency during the test, RX Sensitivity (set/meas ± 3 kHz).

Limits: (lower) -30 kHz, (upper) + 30 kHz

18. RX Sensitivity test MAX_BLOCK [64 max]

Enter the maximum number of blocks transmitted in a single burst during an RX Sensitivity test. A higher number of blocks provides decreased test time.

Limits: (lower) 2 blocks, (upper) 64 blocks

19. RX Splitter/Coupler loss

Enter any signal loss between the Test Set’s DUPLEX OUT port and the MDBS receive ports that is not already entered in parameter “9. RX Cable and Diversity Splitter loss” on page 79. This may be a splitter, coupler, cables, or any other device that affects the signal level into the receiver.

Limits: (lower) 0 dB, (upper) 70 dB

20. RX Test Diversity [0=no, 1=yes]

Set this value to 1 when using both receiver inputs for receiver tests. The setup drawings then display the connections to both inputs of the MDBS through a power splitter. This parameter also affects sniffer, cable loss, and calibration tests setup drawings by indicating the presence of the splitter and any necessary termination.

Limits: 0 and 1 are the only valid entries.

21. Sniffer Injection Level (to test timing)

Enter the signal level used to force the MDBS to a different channel when measuring Sniffer Activation Time. This level should be sufficient to ensure that the transmitter “hops” (changes channel), or shuts down.

Limits: (lower) –137 dBm, (upper) 0 dBm

22. Sniffer Port Pad (Optional)

Enter the value of the attenuator (pad) connected between the MDBS sniffer port and the Test Set’s DUPLEX OUT port.

Limits: (lower) 0 dB; (upper) 90 dB

23. Sniffer Sensitivity (set-and-measure)

Enter the specified signal level that will cause the transmitter to stop transmitting on that channel.

Limits: (lower) –137 dBm, (upper) 0 dBm

24. Sniffer Sensitivity max level to test

Enter the maximum signal level to use when making an iterative Sniffer Threshold test. This level should *always* cause the transmitter to stop transmitting on the current channel. The level should be set higher (“stronger”) than the level specified in parameter 23.

Limits: (lower) –137 dBm, (upper) 0 dBm

25. Sniffer Sensitivity min level to test

Enter the minimum signal level to use when making an iterative Sniffer Threshold test. This level should *not* cause the transmitter to stop transmitting on the current channel. The level should be set lower (“weaker”) than the level specified in parameter 22.

Limits: (lower) –137 dBm, (upper) 0 dBm

26. TX Cable Loss

Enter the amount of signal loss through the cable connecting the transmitter's output to the Test System. This value can also be entered automatically using the Cable Loss test (see parameter "2. Cable/Diversity Splitter Loss Measurement" on page 54). If a splitter or coupler is used, enter that device's loss in parameter 24 - Splitter/Coupler loss.

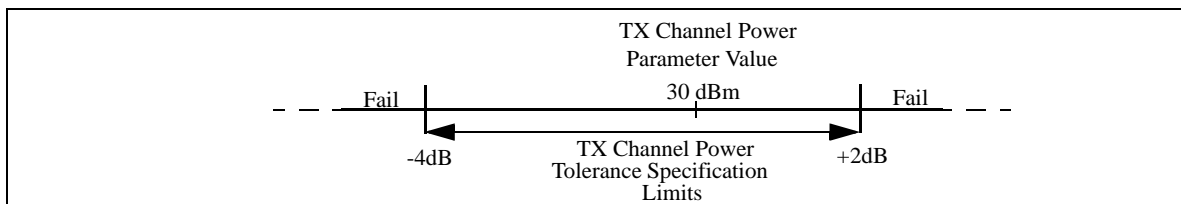
Limits: (lower) 0 dB, (upper) 20 dB)

27. TX Channel Power

Enter the transmitter's specified RF power level. The TX Power and TX Channel Power tests use this as a baseline power measurement value to determine if the transmitter is producing the desired signal level. Test "7. TX Channel Power Tolerance" on page 93 specifies how far above or below this value the measurement can be and still pass when the tests are run.

Figure 5-4 illustrates this relationship; assuming a 30 dBm TX Channel Power setting for this parameter, and assuming the -4 dB and +2 dB TX Channel Power Tolerance values.

Figure 5-4 TX Channel Power parameter and TX Channel Power Tolerance relationship.



Limits: (lower) -50 dBm, (upper) +48 dBm

28. TX Splitter/Coupler loss

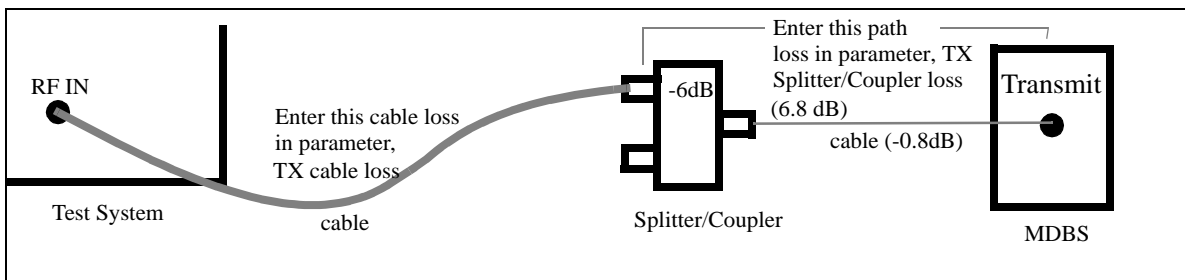
Enter the amount of signal loss through a coupler or splitter (and connecting cable) between the Test System and the transmitter port of the base station.

Limits: (lower) 0 dB, (upper) 70 dB)

For example, for the connections in [Figure 5-5](#) you would enter 6.8dB.

The cable loss between the splitter/coupler and the Test System is entered in parameter 23.

Figure 5-5 Entering Splitter/Coupler and Cable Losses for Transmitter Tests



29. Demonstration Mode [0=normal, 1=demo]

Setting the value to 1 causes the software to imitate testing an MDDBS without an actual base station being connected to the Test System.

Limits: 0 and 1 are the only valid entries.

6

Test Specifications

The Test Specifications set acceptable measurement limit boundaries for the returned test values. An “F” is displayed to the right of a failed measurement as tests are run. This chapter explains what each specification means and how to change them.

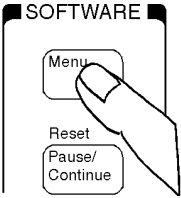




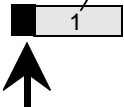


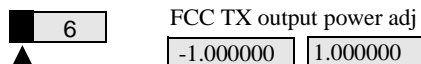


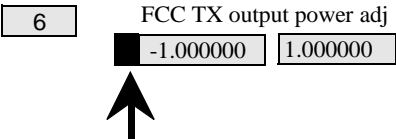
Viewing and Changing Test Specifications

Specifications set upper and lower limits for each measurement. You can tell the software to check both limits, only check the upper or lower limit, or disregard limits entirely.

For example; Test 15, Sniffer Activation Time, verifies that it doesn't take *any longer* than 40 milliseconds for the transmitter to de-key when another signal is detected on the Sniffer port of the MDDBS. Specification 3, Sniffer Activation Time, is where you set the limits for how long it can take the transmitter to switch off before it fails the test. In this case, only the value of specification 3 is checked, since the test only cares that it does switch within 40 milliseconds
















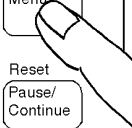
Test specifications are listed on the Software Menu (Pass/Fail Limits) screen. Use the following procedure to access that screen and change limit values:

Figure 6-1 Procedure for Setting Pass/Fail Limits

<p>1 Press the Menu key to display the SOFTWARE MENU screen.</p> <p>If you're in IBASIC, press Shift, Pause/Continue before pressing Menu.</p> 	<p>2 Position the cursor at Spec Pass/Fail limits and select it.</p> <p>Position</p>  <p>Select</p>  <table border="1" data-bbox="1052 443 1382 583"> <tr><td>Freq</td><td>Channel Information</td></tr> <tr><td>Parm</td><td>Test Parameters</td></tr> <tr><td>Seqn</td><td>Order of Tests</td></tr> <tr><td>Spec</td><td>Pass/Fail Limits</td></tr> <tr><td>Proc</td><td>Save/Delete Procedure</td></tr> </table>	Freq	Channel Information	Parm	Test Parameters	Seqn	Order of Tests	Spec	Pass/Fail Limits	Proc	Save/Delete Procedure
Freq	Channel Information										
Parm	Test Parameters										
Seqn	Order of Tests										
Spec	Pass/Fail Limits										
Proc	Save/Delete Procedure										
<p>The TESTS (Pass/Fail Limits) screen is now present on your display.</p>	<p>3 Position the cursor at Spec # field and select it.</p> <p>Position</p>  <p>Select</p>  <p>(Disregard this number)</p> 										
<p>4 Scroll to the desired Spec # and select it.</p> <p>(This Spec # is an example)</p> <p>Scroll</p>  <p>Select</p>  	<p>5 Position the cursor at Lower Limit field and select it.</p> <p>Position</p>  <p>Select</p>  										

Continue on next page

Figure 6-2

<p>6 Use the DATA ENTRY keys to enter a new value, then select it.</p> <p>Enter </p> <p>Select </p> <p>6 FCC TX output power a -0.500000 1.000000</p> <p>(enter your desired value)</p>	<p>7 Position the cursor at Upper Limit field and select it.</p> <p>Position </p> <p>Select </p> <p>CC TX output power adjustment .500000 1.000000 dB</p> <p></p>
<p>8 Use the DATA ENTRY keys to enter a new value, then select it.</p> <p>Enter </p> <p>Select </p> <p>CC TX output power adjustment .500000 0.500000 dB</p> <p>(enter your desired value)</p>	<p>9 Position the cursor at Check field and select it.</p> <p>Position </p> <p>Select </p> <p>Both</p> <p></p>
<p>10 Select which limits should apply to testing and select it.</p> <p>Position </p> <p>Select </p> <p>Choices: Upper Lower Both None</p> <p></p>	<p>11 Press Menu to return to the SOFTWARE MENU screen.</p> <p>Position </p> <p>Select </p> <p>SOFTWARE</p> <p>Menu</p> <p>Reset Pause/ Continue</p> <p></p>

NOTE

How To Interpret Specification Values

It is easy to get confused when using the terms “greater than”, “less than”, “maximum” and “minimum” when dealing with negative numbers. For instance; is a –90 dBm signal greater than or less than a –95 dBm signal? Because it is a negative number, the -95 dBm signal is less than (or “weaker than”) the –90 dBm signal. If –90 dBm is stated as a “maximum” value in the specifications, –88dBm would not pass the test, but –93 dBm would.

Many receiver tests specify the maximum signal level to use to produce a stated response by the MDDBS. If a greater signal level is required to produce that response, the MDDBS is not performing as specified. Using Specification 1 as an example; if the specified Upper Limit for RX Busy Set Threshold is set to –95 dBm, but the Busy/Idle Flag doesn’t get set to Busy until the level is increased to –90 dBm, the test fails. If, however, the Busy/Idle Flag got set at –98 dBm, the test would pass (assuming you haven’t entered a Lower Limit).

Default Values

To determine default values, load the procedure “CDPD” into the Test Set and read the values on the TESTS (Pass/Fail Limits) screen.

1. RX Busy Set Threshold (iterative method)

Enter the maximum allowed signal level that will set the Busy/Idle Flag to Busy.

Enter the value as the Upper Limit, since this is the maximum (strongest) level of signal you should have to put into the receiver to cause the Busy/Idle Flag to get set.

2. RX Sensitivity (iterative method)

Enter the maximum allowed signal level to use when testing for a $\leq 5\%$ Block Error Rate. Enter the value as the Upper Limit.

3. Sniffer Activation Time

Sniffer Activation Time refers to the time it takes the transmitter to stop transmitting after the Sniffer port receives a signal. Enter the maximum allowed time as the Upper Limit.

The Lower Limit can be set to 0.

4. Sniffer Sensitivity (iterative method)

Enter the maximum level of signal into the Sniffer port that should cause the transmitter to stop transmitting. Enter the value as the Upper Limit.

The Lower Limit can be set to 0.

5. Sniffer Test Residual TX Level

Enter the maximum allowed signal level out of the transmitter when it has been turned off due to the presence of a signal detected at the Sniffer port. Enter the value as the Upper Limit. This test is only performed when the ANT IN port is used (see “4. GN Testset Input Port [0=RF IN/1=ANT IN]” on page 77).

The Lower Limit can be set to 0.

6. TX Adjacent Channel Power

Enter the maximum level of signal (relative to the carrier level) allowed at a 30 kHz spacing from the transmitter's center frequency. Enter the value as the Upper Limit.

The Lower Limit can be set to 0.

7. TX Channel Power Tolerance

Enter the minimum and maximum allowed variance from the transmitter channel power (“27. TX Channel Power” on page 84). The values are entered in dB, since the values are relative to the nominal level stated in Parameter 25. Both the upper and lower limits are usually checked.

The Lower Limit specifies how far below the nominal transmitter level the transmitted signal can be.

The Upper Limit specifies how far above the nominal transmitter level the transmitted signal can be.

8. TX First Alternate Channel Power

The First Alternate channel is the channel two channel spacings (60 kHz) from the transmitter’s center frequency. Enter the maximum level of signal allowed, relative to the transmitter’s carrier level. Enter the value as the Upper Limit.

The Lower Limit can be set to 0.

9. TX Frequency Error

Enter the maximum allowed variance in transmitter frequency. The value is entered in parts per million (ppm). For example; a 1ppm error at 850 MHz would equate to a 850 Hz error (one part error for every million parts). Both upper and lower limits are usually entered and checked.

The Lower Limit specifies how far below the nominal transmitter frequency the transmitted signal can be.

The Upper Limit specifies how far above the nominal transmitter frequency the transmitted signal can be.

10. TX Incidental FM

Enter the maximum allowed amount of unintended Frequency Modulation on the transmitter’s signal. Enter the value as the Upper Limit.

The Lower Limit can be set to 0.

11. TX Modulation Index

Modulation index is the ratio of the amount of deviation, divided by the frequency of the modulating waveform. In this case -
(4800 Hz FM Dev.) ÷ (9600 Hz Baud Rate) = 0.500

Enter the Lower and Upper Limits. (.500 ± 1%)

12. TX Second Alternate Channel Power

The Second Alternate channel is the channel three channel spacings (90 kHz) from the transmitter's center frequency. Enter the maximum level of signal allowed, relative to the transmitter's carrier level. Enter the value as the Upper Limit.

The Lower Limit can be set to 0.

Suggested Configuration Process

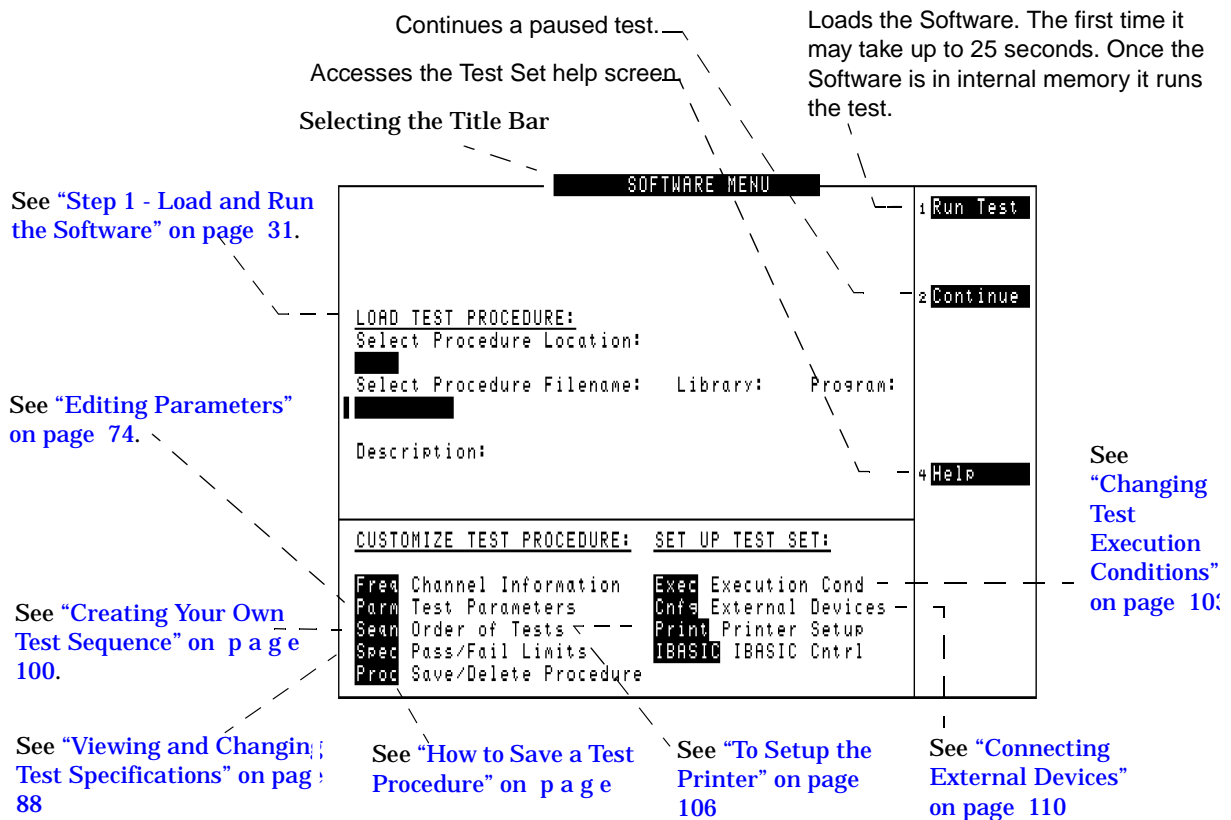
The process for configuring the CDPD software for your testing needs consists of the following ordered steps:

- Step 1.** Edit the Test Parameters to match your system conditions. See [Chapter 5](#) , “Test Parameters,” on page 73. *(Required)*
- Step 2.** Edit the Test Pass/Fail Limits to match your system’s specifications. See [Chapter 6](#) , “Test Specifications,” on page 87. *(Required)*
- Step 3.** Edit the sequence of tests to match your test routine. See [“Creating Your Own Test Sequence”](#) on page 100. *(Optional)*
- Step 4.** Edit the Execution Conditions. These settings specify; where test results are printed, what results get printed, any printout heading, whether to run continuously from test to test or stop between tests, whether or not to automatically run the software when the Test Set is turned on. See [“Changing Test Execution Conditions”](#) on page 103 *(Optional)*
- Step 5.** Specify and configure a printer for printing test results. See [“To print test results:”](#) on page 107 *(Optional)*
- Step 6.** Specify and configure any external devices, such as disk drives. See [“Connecting External Devices”](#) on page 110. *(Optional)*
- Step 7.** Save your configuration as a procedure file for later use. See [“How to Save a Test Procedure”](#) on page 118 *(Recommended)*

Accessing Configuration Screens

Several configuration screens are used to load, enter and edit the various settings that affect software operation. All of these screens are accessed from the SOFTWARE MENU screen that appears when you press the front panel Menu key. See [“Step 1 - Load and Run the Software” on page 31](#) for instructions on how to load the software from the memory card.

Figure 7-1 Test Subsystem



Saving Your Configuration

The Test Set's IBASIC controller loads the software, including parameters, into battery-backed RAM. As long as no other program is loaded or new Test Set firmware is not installed, the program and related parameters will be saved in memory after the Test Set is turned off.

When the Test Set is turned back on, the program will run just like it did the last time you ran it. This prevents you from having to re-load the software each time the Test Set is turned on. However, unless you never run any other programs on your Test Set or never need to change parameters or specifications for testing MDBSs in different cell sites, you need to save your procedure to a more "permanent" location.

After entering the required parameters and specifications information, you should save this information as a "procedure file" to prevent it from getting erased or corrupted by accident. You could then use that procedure for every instance when the same parameters, specifications, and tests are used. See ["How to Save a Test Procedure" on page 118](#).

Required Configuration

You *must* perform the following operations to make accurate, reliable measurements.

Step 1. Enter the Test Parameters. These tell the software:

- Cable and coupler/splitter losses present in the test system.
- Minimum and maximum signal levels to use for receiver tests.
- Bit patterns for decoding your specific base station's data.
- Which Test System input port to use for all tests.

See [Chapter 5](#), “[Test Parameters](#),” on [page 73](#), to understand what each parameter does and how to change them.

Step 2. Enter the Test Specifications. These set the pass/fail limits for each test point. When testing, any failed data points are identified. See [Chapter 6](#), “[Test Specifications](#),” on [page 87](#), to understand what each specification means and how to change them.

Optional Configuration

The following procedures explain how to modify the way the software operates.

Creating Your Own Test Sequence

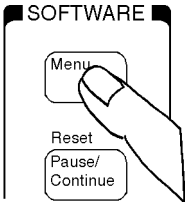

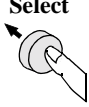



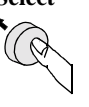
The default operation of the software uses “embedded menus” to move quickly through a series of prompts to select the type of test to perform. Every test is accessible using this method. (This is actually TEST_01: GN Main Menu, as described on [page 53](#).)

An alternate method of testing is to pre-select the exact tests you want to perform, and then run those tests in a sequence. Once the sequence is selected, you can save the sequence as a procedure file for later use.

Follow the instructions on the next page to create a test sequence from the available tests.



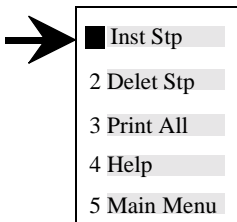

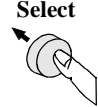
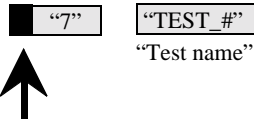

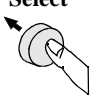
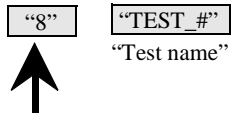

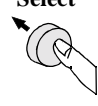
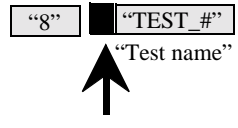

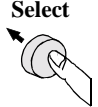
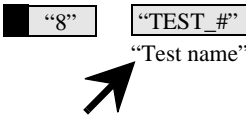
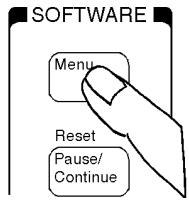
Note: Notice that step #4 scrolls through the list of tests in an existing test sequence in order to insert or delete a test in the sequence. Only TEST_01 is listed when you first get the software. Use k1 (**Insr**t **stp**) to insert lines for new tests (this will duplicate TEST_01 at first). Once a new step has been inserted, you can select that step and change the test by selecting the **Test Name** and selecting from the list of tests (as shown in the procedure).

Figure 7-2 Changing the Order of Tests

<p>1 Press Menu to go to the SOFTWARE MENU screen.</p> 	<p>2 Position cursor at Seqn Order of TESTS and select it.</p> <p>Position</p>  <p>Select</p>  <table border="1" data-bbox="1029 411 1334 558"> <tr><td>Freq</td><td>Channel Information</td></tr> <tr><td>Parm</td><td>Test Parameters</td></tr> <tr><td>Seqn</td><td>Order of Tests</td></tr> <tr><td>Spec</td><td>Pass Fail Limits</td></tr> <tr><td>Proc</td><td>Save/Delete Procedure</td></tr> </table>	Freq	Channel Information	Parm	Test Parameters	Seqn	Order of Tests	Spec	Pass Fail Limits	Proc	Save/Delete Procedure
Freq	Channel Information										
Parm	Test Parameters										
Seqn	Order of Tests										
Spec	Pass Fail Limits										
Proc	Save/Delete Procedure										
<p>The Order of Tests screen is now present on your display.</p>	<p>3 Position cursor at Step # field and select it.</p> <p>Position</p>  <p>Select</p>  <p><i>Example</i></p> <table border="1" data-bbox="964 877 1208 940"> <tr><td>"#"</td><td>"TEST_#"</td></tr> <tr><td></td><td>"Test name"</td></tr> </table> <p>↑</p>	"#"	"TEST_#"		"Test name"						
"#"	"TEST_#"										
	"Test name"										
<p>4 Rotate knob until Step # which precedes the insertion point of the new test you are adding is highlighted, then select it.</p> <p>Rotate</p>  <p>Select</p>  <p><i>For example, select step 7 if you want to insert the new test as step 8.</i></p> <table border="1" data-bbox="915 1247 1192 1415"> <tr><td>"7"</td><td>"TEST_#"</td></tr> <tr><td></td><td>"Test name"</td></tr> <tr><td>"8"</td><td>"New test"</td></tr> </table> <p>↻</p>		"7"	"TEST_#"		"Test name"	"8"	"New test"				
"7"	"TEST_#"										
	"Test name"										
"8"	"New test"										

Continue on next page

Figure 7-3

<p>5 <i>Position cursor at Insrt Stp and select it.</i></p> <p>Position </p> <p>Select </p> 	<p>6 <i>Position cursor at Step # field and select it.</i></p> <p>Position </p> <p>Select </p> 
<p>7 <i>Highlight Step # of the newly inserted test, then select</i></p> <p>Highlight </p> <p>Select </p> 	<p>8 <i>Position cursor at Test Name field, then select it.</i></p> <p>Position </p> <p>Select </p> 
<p>9 <i>Rotate knob until desired Test Name appears, then select it.</i></p> <p>Rotate </p> <p>Select </p> 	<p>10 <i>Press Menu to return to the SOFTWARE MENU screen.</i></p> 

Changing Test Execution Conditions

Test Execution Conditions define how your testing program starts and where and when test output occurs. You may decide to:

- Start the program automatically when the Test System is powered on. (**Autostart**)
- Stop testing when a measurement fails or continue through all of the tests without stopping. (**On UUT Failure**)
- Display (or print) only measurements that fail, or display (or print) all measurements that pass or fail. (**Output Results**)
- Pause between each measurement, or run through the entire test sequence. (**Run Mode**)
- Display output on CRT only, or display on CRT and print hardcopy. (**Output Destination**)

NOTE

If printing test results is desired, after selecting **Printer** additional steps are necessary to connect and configure the printer. See [“Printing” on page 105](#).

- Enter a title for an output heading for the displayed or printed results. (**Output Heading**) Select the field with the knob and enter the output heading by selecting the appropriate letters and the select **Done**.

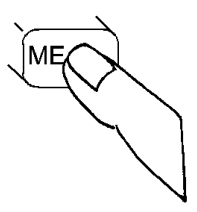
Test execution conditions are located on the TESTS (Execution Conditions) screen. Press **Menu** and select **Exec - Execution Cond** to display them. To change a default setting, position the cursor at the desired field. Pressing the knob (“selecting”) will toggle the underlined selection.

Test Execution Conditions settings (except for **Autostart**) are not retained after a power-down/ power-up cycle, and will return to their default settings. They are not stored on the memory card when a test procedure is saved.

Figure 7-4


1 Press **MENU** to display the **SOFTWARE MENU** screen.

If you are in IBASIC, press SHIFT, CANCEL before pressing TESTS.

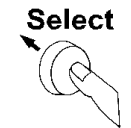


2 Position cursor at **Exec** Execution Cond and select it.

Position



Select



Exec	Execution Cond
Cnfg	External Devices
Print	Printer Setup
IBASIC	IBASIC Cntrl

3

Select Printer to output test procedure results to the CRT and a printer.

Select Failures to display only the CRT and printer measurements that fail.

Select Stop to stop a Test Procedure when a failure occurs.

Select Single Step to stop a Test Procedure at the end of each measurement.

TESTS (Execution Conditions)

Output Results To:
Crt/Printer

Output Results For:
All/Failures

Output Heading:
[REDACTED]

If Unit-Under-Test Fails:
Continue/Stop

Test Procedure Run Mode:
Continuous/Single Step

Autostart Test Procedure on Power-Up:
Off/On

1 Run Test

2 Continue

+ Help

5 Main Menu

To Screen

RF GEN

RF ANL

AF ANL

SCOPE

SPEC ANL

ENCODER

DECODER

RADIO INT

More

TESTEXEa

104

Chapter 7

C:\Spk6381\E6381A_CDPD\Book\Configur.fm

Printing

You can print any of the following:

- Test results
- TESTS screens
 - "External Devices" (Edit Cnfg)
 - "Order of Tests" (Edit Seqn)
 - "Channel Information" (Edit Freq)
 - "Pass/Fail Limits" (Edit Spec)
 - "Test Parameters" (Edit Parm)

How to Print

The basic steps to printing are listed below. A detailed description of each of these steps is at the end of this section.

1. Check to see if your printer is supported by the Test Set (see ["Supported Printers" on page 105](#)).
2. Determine if your printer requires serial, parallel, or HP-IB connection. Connect the printer to the appropriate port on the Test Set (see ["Printer Connection" on page 106](#)).
3. Configure the Test Set for your printer and its interface (see ["Suggested Configuration Process" on page 96](#)).
4. Define what to print (see ["To print test results:" on page 107](#)).

Supported Printers

- HP® ThinkJet
- HP QuietJet
- HP PaintJet
- HP DeskJet
- Epson FX-80
- HP LaserJet
- Epson LQ-850

If you do not have one of these printers, consult your printer's manual for the correct printer settings to emulate one of the supported printers.

Printer Connection

HP-IB Connection

An HP-IB printer can be connected to the Test Set's rear-panel HP-IB connector with an HP-IB cable.

Serial Connection

A serial printer can be attached to the SERIAL 9 port. This is the only serial port used for printing. Use a standard serial printer cable.

Parallel Connection

A parallel printer can be attached to the PARALLEL 15 port. This is the only parallel port used for printing. Use a standard parallel printer cable.

To Setup the Printer

- Step 1.** Press the **Menu** key.
- Step 2.** Select **Print - Printer Setup** from the **SET UP TEST SET** list.
- Step 3.** Position the cursor at **Model** and select the desired printer.
- Step 4.** Position the cursor at **Print Port** and select the desired port.
- Step 5.** HP-IB only: Position the cursor at **Printer Adrs** and enter the HP-IB address for your printer (0-30).
- Step 6.** Set the following options if desired:
 - **Lines/Page** (controls the number of lines, 20-120, printed on a page before a form feed is sent to the printer)
 - **FF at Start** (to cause a form feed at the start of a test sequence)
 - **FF at End** (to cause a form feed at the end of a test sequence)
- Step 7.** From the **To Screen** menu, select **More**.
- Step 8.** Press the **Shift** key, then press the **Inst Config** key to go to the I/O CONFIGURE screen.
 - a.** For Serial printers, set the **Serial Port** field to **Port 9** and set the fields below it to match those needed by your printer (baud rate, parity, data length, stop length, flow control).
 - b.** For HP-IB Printing, set the **Mode** field to **Control**.
- Step 9.** Press the **Menu** key to return to the SOFTWARE MENU screen.

To print test results:

- Step 1.** Press the **Menu** key.
- Step 2.** Select **Print - Printer Setup** from the **SET UP TEST SET** list.
- Step 3.** Position the cursor at **Output Results To** and select **Printer**.
- Step 4.** Position the cursor at **Output Results For** and select **All** if you want all results printed, or **Failures** if you want failures only printed.
- Step 5.** (Optional) Position the cursor at **Output Heading** and enter your desired heading.

To send Escape Sequences to the printer

The Test Set may be used to send escape sequences to control printer options such as pitch, margins, paper size, and so forth. The software comes with some pre-defined escape sequences compatible with HP printers, listed in Table 10, or you have the option to enter others which are compatible with your printer (use your printer's user's manual for the available print features and corresponding escape sequences).

The software already has an implied escape character for the first sequence, you only need to enter the escape sequence following the escape character. However, if you are linking two or more sequences together, you must use the ~ to indicate the escape character between each sequence. If the sequence exceeds the space allotted in the options field, you may continue with additional escape sequences in the next available **Options** field. You must however, still enter **Escape Seq** in the **Calling Name** field and the appropriate address in the **Addr** field for all subsequent entries.

**How to send an
Escape
Sequence:**

- Step 1.** Press the **Menu** key.
- Step 2.** Select **Cnfg - External Devices** from the **SET UP TEST SET** list.
- Step 3.** Position the cursor at the **Inst#** field and select it.
- Step 4.** Rotate the knob until an empty **Calling Name** field appears, and select it.
- Step 5.** Position the cursor at the **Calling Name** field and select it.
- Step 6.** Select **Escape Seq** from the **Choices** menu.
- Step 7.** Position the cursor at the **Addr** (address) field and select it.
- Step 8.** Using the **DATA ENTRY** keypad, enter **9** for serial printers, **15** for parallel printers, or **70X** for HP-IB printers, then press **ENTER**.
- Step 9.** Position the cursor at the **Options** field (directly under **Calling Name**) and select it.

Step 10. Select the desired escape sequence from the **Choices** menu if applicable, or enter an appropriate sequence using the list of characters below the choices.

Table 7-1 Escape Sequence Definitions for HP Printers

Escape Sequence	Print Feature
&l66P	Sets page length to 66 lines
&l72P	Sets page length to 72 lines
&l6D	Sets lines per inch to 6 lines
&l8D	Sets lines to inch to 8 lines
(s12h12v6T	Selects 12 characters per inch 12/72 inch character height gothic typeface
&a9L~&l6E	Sets left margin to 9 characters top margin to 6 lines
(s12h12v6T~&a9L~&l6E	Selects 12 characters per inch 12/72 inch character height gothic typeface left margin to 9 characters top margin to 6 lines
&l8d88P	Selects 8 lines per inch 88 lines per page
&l8d96P	Selects 8 lines per inch 96 lines per page
(s16.67h12V~&a17L~&l6E	Selects 16.67 characters per inch 12/72 inch character height left margin to 17 characters top margin to 6 lines

To print TESTS screens:

TESTS screens include:

- "External Devices"
- "Order of Tests"
- "Channel Information"
- "Pass/Fail Limits"
- "Test Parameters"

The same general process is used to print the information for all of the above TESTS screens.

Step 1. Make sure that your printer is properly connected and configured as explained earlier in this section.

Step 2. Press the **Menu** key.

Step 3. Select the **CUSTOMIZE TEST PROCEDURE** screen of your choice.

Step 4. Press **k3 (Print All)**.

Step 5. Press the **Menu** key to return to the **SOFTWARE MENU** screen.

To print exactly what appears on a test screen, press the **Print** key.

Connecting External Devices

The TESTS (External Devices) screen is used with various software packages to configure the Test Set to communicate with other devices over serial or HP-IB connections. The CDPD software uses this screen for configuring Data Collection.

Data Collection sends your test data to another device for printing or storage. Stored data can then be retrieved and used for a variety of purposes, such as comparing past and present test results. Data can be stored to a SRAM memory card or to a PC.

Data Collection (Saving and Retrieving Test Results)

The software has the capability to save test results to an SRAM PC (memory) card or to a PC.

Collection to a PC Card

You need to make entries in the **External Devices (Edit Config)** screen to describe the type of data collection you are using.

**To configure
External
Devices entries:**

- Step 1.** Press the **Menu** key to access the SOFTWARE MENU screen. If you are currently running software, press **Shift, Pause/Continue** first to stop program operation.
- Step 2.** Select **Cnfg - External Devices** from the SET UP TEST SET list at the bottom of the screen.
- Step 3.** Position the cursor at the **Calling Name** field and select it.
- Step 4.** Scroll the cursor down and select **DATA COLLECTION**, then select **Done**.
- Step 5.** Position cursor to the **Addr** field and select it.
- Step 6.** Using the DATA ENTRY keys, enter **1** if you are saving data to a PC card, or enter **9** if you are saving data to a PC connected to the Test Set's SERIAL 9 port.

**To Specify the
File Type**

The test software supports data storage on Disk Operating System PC cards. Storage can be to any of the following file types:

- ASCII
- BDAT

You can specify the file type in the **Options** field immediately below **DATA COLLECTION**. If no file type is entered, the Software defaults to "DOS".

**To Specify an
Optional File
Extension**

To add a file extension to the file name, you can either select **(DAT)**, to automatically identify it as a DATA file, or select **(EXT)** and change the three letters to some other preferred extension.

**To Specify the
File (Record)
Size**

If you are using an ASCII or BDAT file, you can specify the number of 256 byte records allocated to the file. The DOS file is automatically updated as data is stored, so record allocation is not required. You can enter the **REC=** after the file type. For example, to use an ASCII file with 200 records of 256 bytes each, you will enter **ASCII REC=200** into the **Options** field.

The default number of records used when no **REC=** entry is made is 80.

Items in the **Options** field can be separated by a comma or a space.

See ["Initializing a PC Card" on page 117](#) if using a new memory card.

Data Collection to a PC

Test results can be output through the SERIAL 9 port. A variety of devices can receive the data. An HP Palmtop computer, PC, laptop, or terminal can be used. A terminal emulator can log the test results to a file. Examples of terminal emulator programs are AdvanceLink® from HP and ProComm® from DataStorm Technologies.

For example: Configuring an IBM-Compatible PC with AdvanceLink for DOS

Step 1. Load and run AdvanceLink on your PC.

Step 2. Use the following [Table 2 on page 112](#), [Table 2 on page 112](#), and [Table 2 on page 113](#), to set the *Global Configuration*, *Terminal Configuration*, and *Remote Configuration* settings.

Table 7-2 Global Configuration Settings

FIELD	SETTING	FIELD	SETTING
Keyboard	USASCII	Memory Size	32K
Personality	HP	Plotter I/F	None
Language	English	HP Mode	Yes
Terminal Mode	Alphanumeric	Video Type	<i>Select your display type</i>
Remote to	<i>enter PC's serial port #</i>	Forms Path	<i>Enter path if used</i>
Printer I/F	None	Screen Size	<i>Enter the size</i>

Table 7-3 Terminal Configuration Settings

Field	Setting	Field	Setting
Terminal ID	2392A	Esc Xfer(N)	YES
Local Echo	OFF	ASCII 8 Bits	YES
CapsLock	OFF	FldSeparator	US
Start Col	01	BlkTerminator	RS
Bell	ON	ReturnDef	CR
XmitFnctn(A)	NO	Copy	Fields
SPOW(B)	NO	Type Ahead	NO
InhEolWrp(C)	NO	ROW Size	80
Line/Page(D)	LINE	Host Prmpt Char	D1
InhHndShk(G)	NO	Horiz. Scroll. Incr.	08

Table 7-3 Terminal Configuration Settings

Field	Setting	Field	Setting
Inh DC2(H)	NO	Large [+] Key	+

Table 7-4 Remote Configuration Settings

FIELD	SETTING	FIELD	SETTING
Baud Rate	4800	SR(CH)	LO
Parity/Data Bits	None/8	Recv Pace	None
Eng Ack	No	Xmit Pace	None
Asterisk	OFF	CS(CB)Xmit	NO
Chk Parity	NO		

To set up for data collection to a PC:

- Step 1.** Press the **Menu** key.
- Step 2.** Select **Cnfg -External Devices** from the **SET UP TEST SET** list.
- Step 3.** Position the cursor to the **Calling Name** field and select it.
- Step 4.** Select **DATA COLLECTION** from the list of choices.
- Step 5.** Position the cursor to the **Addr** field and select it.
- Step 6.** Using **DATA ENTRY** keypad, enter **9** and press **ENTER**. The first entered line should look like this:

```
1 DATA COLLECTION [blank] 9
```

Configuration for Terminal Operation

It is preferable to enter long strings of characters into fields, such as the TESTS (IBASIC Controller) command line, using a terminal. The characteristics of the serial port, when used for instrument control from a terminal or terminal emulator, are determined by settings on the Test Set's I/O CONFIGURE screen (press Shift, then Inst Config).

Set the following:

- `Serial In` to `Inst`
- `IBASIC Echo` to `On`
- `Inst Echo` to `On`

Set the remaining configuration entries to match the settings of your terminal or PC program.

PC Cards (Memory Cards, PCMCIA Cards)

PC cards are inserted into the slot on the Test Set's front panel. The card is powered by the Test Set while it is inserted. Arrows printed on the card indicate the direction and orientation of card insertion.

PC cards are used to store or retrieve the following:

- Software code
- A Procedure, supplied by Agilent Technologies, and containing:
 - A default TEST sequence
 - Default test parameter values
 - Default pass/fail limit (specification) values
- A Library file
- Procedures you make, optimized for your application
- Data collection files
- Channel Information
- User defined keys

Two types of memory cards are available:

- Static Random Access Memory (SRAM)
- One-Time Programmable (OTP)

SRAM cards have read and write capability. Once programmed, OTP cards have read-only capability.

The software memory card can be removed after the program is loaded into the Test Set memory. The program will remain in the Test Set's RAM after a power-down/power-up cycle, until a new program is loaded. Loading a new program will replace the existing program.

SRAM PC (Memory) Cards

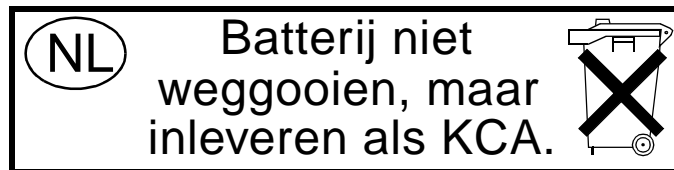
A Static Random Access Memory (SRAM) PC Card can be used to store test results and procedures you make. The following parts can be used.

Table 7-5 SRAM PC Card Part Numbers

Memory	Agilent Part Number
64 kilobytes	83230A (0950-2634)
256 kilobytes	83233A (0950-2640)
1 megabyte	83231A (0950-2635)

SRAM memory cards use a lithium battery (part number CR 2025 or Agilent Technologies part number 1420-0509). Programs and data will be retained for over one year if the memory card is stored at 25° C. The memory card is powered by the Test Set while it is inserted. Replace the battery while the memory card is inserted into a powered-up Test Set. To retain data and programs, it should be replaced annually. The write-protect switch on an SRAM memory card will write protect the card when it is set toward the outside of the card.

Figure 7-5



PC Card Storage Space

Procedures use 12-16 records each. A Library uses 20-35 records. A single library must be included on the card. A record is 256 bytes. Approximately 11 kilobytes of overhead is required on each card.

Use the following formula to estimate the storage space needed:

$$\text{Storage Space (in kilobytes)} = (\text{Number of Procedures} \times 4.1) + 20$$

For example, if you want to save ten different procedures, you will need 61 kilobytes of memory. The 64 kilobyte or 128 kilobyte card is sufficient.

The storage space you need for data collection depends on the number of test results that are saved. You will need approximately 4 kilobytes per page of test results that you save. A page of test results is about 57 lines of CRT or printer output.

The storage space of smaller SRAM cards can be quickly used. If you are collecting large quantities of data, data collection using a PC or printer may be preferable.

Initializing a PC Card

There are several ways to initialize a PC card. Choose the way that is easiest for you:

- Load and run the CARD_INI procedure in the E8304A Software and follow the instructions. Be sure to select the DOS format.
- Press **Shift**, then **Inst Config** to access the I/O CONFIGURE screen. Insert the uninitialized card and select the **PCMCIA - Format Card** field. The prompt "Erase and format the PCMCIA Card? (Yes/NO)" is displayed. Press the **Yes On/Off** key.
- Press **Menu** to access the SOFTWARE MENU screen, and then select **Proc - Save/Delete Procedure**. Insert the card and press **k3 (Format)**. The prompt "Erase and format the PCMCIA Card? (Yes/NO)" is displayed. Press the **Yes On/Off** key.

How to Save/Delete Procedures

Figure 7-6 TESTS (Save/Delete Procedure) screen

```
TESTS (Save/Delete Procedure)
SAVE/DELETE TEST PROCEDURE:
Select Procedure Location:
| Card
Enter Procedure Filename:
[REDACTED]
Enter Description for New Procedure:
[REDACTED]
SAVE PROCEDURE INFORMATION:
Procedure Library:
Current/[NO LIB]
Code Location:
Card
Password:
[REDACTED]
1 Save Proc
2 Del Proc
3 Init Card
4 Help
5 Main Menu
```

A test procedure is a collection of channel information, test parameters, testing order, and pass/fail limits saved in a file that customizes the test Software to a specific application. Normally, procedures are saved on a PC card.

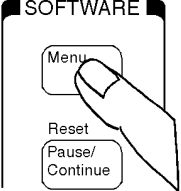

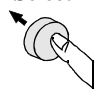

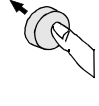
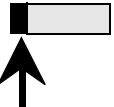

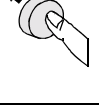
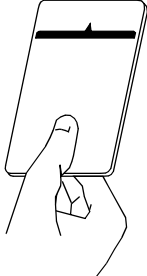
When you save a procedure you will be saving channel information, test parameters, pass/fail limits, and testing order, plus a library that contains the names of all test parameters, pass/fail limits, and tests that are resident in the Software. The library file comes from the Software and cannot be modified. The library file will be automatically saved on the card or disk that is being used to store the new test procedure.

Running a Saved Procedure You cannot run your procedure without the original Software program. The procedure contains the “operating details” for the tests, but does not contain the actual test code. After selecting your saved procedure, you must insert the original Software OTP (One Time Programmable) PC card containing the full program for your procedure to run.

How to Save a Test Procedure



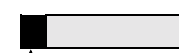


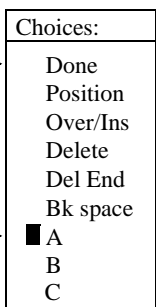

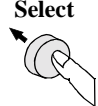



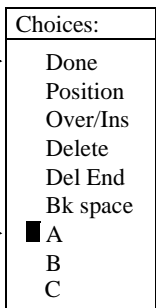

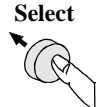

Figure 7-7, Figure 7-8, and Figure 7-9 show how to save a new procedure to a memory card.

Figure 7-7 How to save a test procedure

<p>1 Press the Menu key to display the SOFTWARE MENU screen.</p> <p><i>If you are in IBASIC, press Shift, Pause/Continue before pressing Menu.</i></p> 	<p>2 Position cursor at Proc Save/Delete Procedure and select it.</p> <p>Position</p>  <p>Select</p>  <table border="1" data-bbox="1036 401 1365 562"> <tr><td>Freq</td><td>Channel Information</td></tr> <tr><td>Parm</td><td>Test Parameters</td></tr> <tr><td>Seqn</td><td>Order of Tests</td></tr> <tr><td>Spec</td><td>Pass/Fall Limits</td></tr> <tr><td>Proc</td><td>Save/Delete Procedure</td></tr> </table>	Freq	Channel Information	Parm	Test Parameters	Seqn	Order of Tests	Spec	Pass/Fall Limits	Proc	Save/Delete Procedure
Freq	Channel Information										
Parm	Test Parameters										
Seqn	Order of Tests										
Spec	Pass/Fall Limits										
Proc	Save/Delete Procedure										
<p>The TESTS (Save/Delete Procedure) screen is now on your Test Set display.</p>	<p>3 Position cursor at Select Procedure Location and select it.</p> <p>Position</p>  <p>Select</p>  <p>Select Procedure Location:</p> 										
<p>4 Position the cursor at Card and select it.</p> <p>Position</p>  <p>Select</p>  <table border="1" data-bbox="532 1241 667 1381"> <tr><td>Choices:</td></tr> <tr><td>■ Card</td></tr> <tr><td>RAM</td></tr> <tr><td>Disk</td></tr> </table> <p><i>(You can also save procedures to an internal RAM disk or external disk drive.)</i></p>	Choices:	■ Card	RAM	Disk	<p>5 Put an initialized PC card in the front-panel slot.</p> <p>For detailed memory card initialization instructions, see “Initializing a PC Card” on page 117</p> 						
Choices:											
■ Card											
RAM											
Disk											


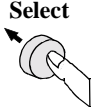





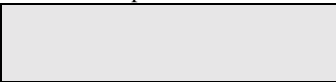

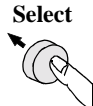
Continue on next page

Figure 7-8 How to save a test procedure

<p>6</p> <p>Position</p>  <p>Select</p> 	<p>Enter Procedure Filename:</p> 	<p>7</p> <p>Position</p>  <p>Select</p> 	<p>Select characters to name the Procedure, then select Done.</p> 
<p>8</p> <p>Position</p>  <p>Select</p> 	<p>Enter Description for</p> 	<p>9</p> <p>Position</p>  <p>Select</p> 	<p>Select characters for the description, then select Done.</p> 
<p>10</p> <p>Position</p>  <p>Select</p> 	<p>Procedure Library:</p> <p><u>C</u>urrent / [NO LIB]</p> <p>(The underline indicates which option is selected. Pressing the knob changes the selection.)</p>	<p>11</p> <p>Position</p> 	<p>Position the cursor at Code Location: and select it.</p> <p>ROM</p>

Continue on next page

Figure 7-9 How to save a test procedure

<p>6 Position the cursor at Enter Procedure File... and select it.</p> <p>Position </p> <p>Select </p> <p>Enter Procedure Filename: </p>	<p>7 Select characters to name the Procedure, then select Done.</p> <p>Position </p> <p>Select </p> <p>Choices: Done Position Over/Ins Delete Del End Bk space <input checked="" type="checkbox"/> A B C</p>
<p>8 Position the cursor at Enter Procedure File... and select it.</p> <p>Position </p> <p>Select </p> <p>Enter Description for </p>	<p>9 Select characters for the description, then select Done.</p> <p>Position </p> <p>Select </p> <p>Choices: Done Position Over/Ins Delete Del End Bk space <input checked="" type="checkbox"/> A B C</p>
<p>10 Position the cursor at Procedure Library: and select Current.</p>	<p>11 Position the cursor at Code Location: and select it.</p>

A **Standard Formulas and Conversions**

IMPORTANT

This section provides some formulas for calculating and converting power and voltage values when entering parameter and specification values.

Standard Formulas and Conversions

(All logs are base 10)

Equation A-1 Power Gain or Loss

$$dBm = 10\log\frac{P_2}{P_1}$$

Where P₂=Power Out and P₁=Power In

Equation A-2 Watts ⇒dBm

$$dBm = 10\log\frac{P}{0.001\text{Watt}}$$

Where P=Power in Watts

Equation A-3 Watts ⇒dBW

$$dBW = 10\log\frac{P}{1\text{Watt}}$$

Equation A-4 Volt ⇒dB μ V

$$dB\mu V = 20\log(V \times 1 \times 10^6)$$

1 Volt = 20log(1 × 1,000,000) = 120 dB μ V

Equation A-5 dBm ⇒mW

$$mW = 10^{\frac{dBm}{10}}$$

Equation A-6 dBm ⇒W

$$W = \frac{10^{\frac{dBm}{10}}}{1000}$$

Equation A-7 Parts Per Million

$$ppm = \frac{N \times 1 \times 10^6}{F}$$

Where: N = frequency error
F = center frequency

For example: An 800 Hz frequency error (N) from an 800 MHz center frequency (F):

Equation A-8

$$1ppm = \frac{800Hz \times 1,000,000}{800,000,000Hz}$$

Equation A-9 dB μ V⇒W

$$W = \frac{\left(10^{\frac{dB\mu V}{20}}\right)^2 \times 10^{-12}}{Z}$$

Where Z = impedance (50 Ω when measuring with the Agilent Technologies E6381A).

Equation A-10 W⇒dB μ V

$$dB\mu V = 20 \log \frac{\sqrt{WZ}}{10^{-6}}$$

Where Z = impedance (50 Ω when measuring with the Agilent Technologies E6381A).

Equation A-11 **$\text{dB}\mu\text{V} \Rightarrow \text{dBm}$**

$$dBm = dB\mu V - 107$$

Example: $120\text{dB}\mu\text{V} - 107 = 13\text{dBm}$

Equation A-12 **$\text{dBm} \Rightarrow \mu\text{V}$**

$$\mu V = 10^{\frac{dBm + 107}{20}}$$

Equation A-13 **$\mu\text{V} \Rightarrow \text{dBm}$**

$$dBm = (20\log(\mu V)) - 107$$

Example: For a level of $850\mu\text{V}$: $(20 \times (\log 850)) - 107 = -48.4\text{dBm}$

Glossary

A

ACC The Area Color Code is assigned to a serving MD-IS. This value is part of the color code broadcast by the MD-IS at the start of each physical block. The M-ES uses the ACC to determine if it has done a cell transfer into a new serving MD-IS, and therefore needs to go through a registration sequence. The ACC is an integer from 0 to 7 (inclusive).

C

CDPD Cellular Digital Packet Data. A system for transmitting and receiving blocks of digitally encoded information using existing cellular telephone network frequencies.

G

GCC A Group Color Code is assigned to every CDPD cell. It is part of the color code broadcast by the MD-IS at the start of each physical block. It is used by an M-ES to determine if it is incorrectly picking up an RF channel that is not assigned to the current cell. The Group Color Code is an integer from 0 to 31 (inclusive).

M

MD-IS Mobile Data Base Station. This is the receiver/transmitter that relays data between the M-ES and the MD-IS. It is located at a fixed site; typically in a cellular phone site.

M-ES Mobile End Station. This is the receiver/transmitter that is the originator or final receiver of the data. It may be at a fixed location or installed in an automobile or other mobile carrier.

MD-IS Mobile Data Intermediate Station. This is the point where data is exchanged between the wire-line phone system and the MD-IS.

R

Reference Channel A forward channel used to provide a reference signal level to the M-ES. The moving M-ES uses this signal to help it determine the best cell to transfer to by making a signal strength measurement of each of the surrounding cells.

A

ACCESSORY KIT, 44
Active Ch(annel) Streams, 68
ADC
 definition, 127
Adjacent Channel Power, 58
AdvanceLink, 112
Agilent E6381A operation, 47
Agilent sales offices, 24
Agilent service centers, 24
Alternate Channel Power, 58
ANT IN, 77
Area Color Code, 68
Autostart, 103

B

base station
 definition, 127
BLER Average Time, 71
BLER Threshold, 71
Busy Set Threshold, 77

C

Cable Loss, 84
Cable Loss Measurement, 54
CABLOSS, 43
Calibration
 GMSK Deviation Calibration, 56
 Power Measurement, 55
Calibration, Center Frequency, 56
CALs, 43
CDPD procedure, 43
Cell Number, 66, 68
Center Frequency Calibration, 56
Channel Stream Identifier, 66
configuration
 for data collection, 110
 for terminal or PC operation, 114
configuration process, 96
configuration screens, 97
configuration, test system, 95
configuring an IBM-compatible PC with Agilent
 AdvanceLink, 112
connecting a printer, 106
connections
 parallel printer, 106
 serial printer, 106
connections for receiver/sniffer tests, 52
connections for transmitter and PDU display tests, 51

conventions used in this manual, 11
conversions
 standard formulas, 124
coupler/splitter, 85
creating test procedures, 118

D

data collection
 entering the configuration for, 111
 example configuration, 111
 saving to a PC card or disk, 110
 to a PC, 112
 to a PC, setting up, 113
Dedicated Channel Flag, 66
deleting test procedures, 118
DEMO, 43
Demo Mode, 27
Demonstration Mode, 85
Display CAP PDU, 71
Display CC PDU, 68
Display CQP PDU, 70
Display CSI PDU, 66

E

Edit Configuration
 data collection to a PC, 113
editing parameters, 74
equipment, required, 29
ERP Delta, 68
escape sequences, 107

F

Face, 69
firmware revision, 46
firmware upgrades, 46
Firmware, Software Revision Info, 72
Frequency Error, 57
front-panel control characters, 114

G

Getting Started, 27
GMSK Deviation Calibration, 56
GN Main Menu (accesses all tests), 53

H

HP-IB printer, 106
HP-IB printer connections, 106

I

Incidental FM, 58

initializing an SRAM PC card, 117
input port, 77
installation kit, 44

L

limits, upper & lower, 88
load and run the software, 31

M

manual use of the test system, 34
manuals, 18
Max Blocks, 71
Max Count, 72
Max Entrance Delay, 72
Max Power Level, 67
Max TX Attempts, 71
memory cards
 are used for, 115
 initializing, 117
 OTP, 115
 removing, 115
 SRAM, 115
 storage space needed, 117
Min Count, 72
Min Idle Time, 71
Modulation Index, 57

O

optional configuration, 100
order of tests
 printing, 105
Output Destination, 103
Output Heading, 103
Output Results, 103

P

parallel printer connections, 106
Parameters
 Decode Status Flag template, 80
 Demonstration Mode, 85
 GN Signals Present, 76
 GN sound BEEP in menu, 76
 GN System, 76
 GN Testset Input Port, 77
 RX Busy Set Threshold, 77
 RX Busy Threshold max level to test, 77
 RX Busy Threshold min level to test, 77
 RX Busy/Idle Flag template, 78
 RX Cable Loss, 79
 RX Decode Stat timing, 80
 RX Fwd Channel Control Flag test level, 81

- RX Sensitivity level (set and measurement), 81
 - RX Sensitivity max level to test, 82
 - RX Sensitivity min level to test, 82
 - RX Sensitivity test frequency offset, 82
 - RX Sensitivity test
 - MAX_BLOCK, 82
 - RX Splitter/Coupler loss, 82
 - Sniffer Injection Level, 83
 - Sniffer Port Pad, 83
 - Sniffer Sensitivity (set and measure), 83
 - Sniffer Sensitivity max level to test, 83
 - Sniffer Sensitivity min level to test, 83
 - TX Cable Loss, 84
 - TX Channel Power, 84
 - TX Splitter/Coupler loss, 85
 - parameters
 - printing, 105
 - pass/fail limits
 - printing, 105
 - PC
 - collecting data to, 112
 - Power Measurement Calibration, 55
 - Power Product, 67
 - power, channel, 84
 - print options
 - pitch, margins, paper size, typeface, 107
 - printer
 - HP-IB, 106
 - serial, 106
 - printers supported, 105
 - printing, 105
 - TESTS Screens, 110
 - procedures on the OTP card, 43
 - procedures, save/delete, 118
 - product description, 41
 - program
 - stored in Test Set memory, 115
 - programming information, 47
 - Protocol Version, 66
- R**
- REC=
 - default entry, 111
 - entering record number, 111
 - REC= to set record size, 111
 - Reference Channel, 68
 - repair information, 47
 - required configuration, 99
 - required equipment, 29
 - RF Channels, 69
 - RF in/out, 77
 - RSSI Average Time, 70
 - RSSI Bias, 69
 - RSSI Hysteresis, 70
 - RSSI Scan Delta, 70
 - RSSI Scan Time, 70
 - Run Mode, 103
 - run test, 31
 - running tests, 95
 - overview, 99
 - RX Busy Set Threshold (iterative), 61
 - RX Busy Set Threshold (set-and-measure), 60
 - RX Cable Loss, 79
 - RX Forward Channel Control Flag, 59
 - RX Sensitivity, 81
 - RX Sensitivity (iterative), 64
 - RX Sensitivity (set/meas, +/- 3 kHz), 63
 - RX Sensitivity (set-and-measure), 62
 - RX Splitter/Coupler loss, 82
- S**
- safety warnings and cautions, 15
 - saving test procedures, 118
 - SEQN, 43
 - serial printer, 106
 - serial printer connections, 106
 - Service Provider Identifier, 66
 - Sniffer Activation Time, 65
 - Sniffer Sensitivity, 83
 - Sniffer Threshold (iterative), 65
 - Sniffer Threshold (set-and-measure), 64
 - software
 - overview, 99
 - software revision, 46
 - software upgrades, 46
 - Software/Firmware Revision Info, 72
 - Specifications
 - RX Busy Set Threshold (iterative method), 92
 - RX Sensitivity (iterative method), 92
 - Sniffer Sensitivity (iterative method), 92
 - Sniffer Test Residual TX Level, 92
 - TX Channel Power Tolerance, 93
 - TX First Alternate Channel Power, 93
 - TX Frequency Error, 93
 - TX Incidental FM, 93
 - TX Second Alternate Power, 94
 - specifications, entering, 93
 - Splitter/Coupler, 82
 - SPNI, 66
 - SRAM memory card, 44
 - standard formulas and conversions, 124
 - stopping the program
 - using Test Execution Conditions, 103
- T**
- terminal emulator
 - configuration, 114
 - DataStorm Technologies, Inc. ProComm, 112
 - Agilent AdvanceLink, 112
 - test descriptions, 49
 - Test Execution Conditions, 103
 - test parameters, 73
 - test sequence, creating, 100
 - Test Specifications, 93
 - test system configuration, 95
- TESTS**
- Cable Loss Measurement, 54
 - Center Frequency Calibration, 56
 - Display All PDUs, 72
 - Display CAP PDU, 71
 - Display CC PDU, 68
 - Display CQP PDU, 70
 - Display CSI PDU, 66
 - GMSK Deviation Calibration, 56
 - GN Main Menu (accesses all tests), 53
 - Power Measurement Calibration, 55
 - RX Busy Set Threshold (iterative), 61
 - RX Busy Set Threshold (set-and-measure), 60
 - RX Forward Channel Control Flag, 59
 - RX Sensitivity (iterative), 64
 - RX Sensitivity (set/meas, +/- 3 kHz), 63
 - RX Sensitivity (set-and-measure), 62
 - Sniffer Activation Time, 65
 - Sniffer Threshold (iterative), 65
 - Sniffer Threshold (set-and-measure), 64

- Software/Firmware Revision
 - Info, 72
 - TX Test (all), 57
- tests
 - running, 95
- Troubleshooting, 35
- TX Cable Loss, 84
- TX Channel Power, 58, 84
- TX Power, 57
- TX Splitter/Coupler loss, 85
- TX Test (all), 57

U

- upgrades
 - firmware, 46
 - software, 46
- USER keys, 12

W

- Wide Area Service Identifier, 67